



Submittal Data Sheet

Indoor Unit Model#: AC-I-4860ACL-21

Outdoor Unit Model#: AC-I-48AC14

R32 48K 21" EVAPORATOR A-COIL & 48K TOP-DISCHARGE AC-COOLING ONLY CONDENSER

Location:	Approval:
Engineer:	Date:
Submitted to:	Construction:
Submitted by:	Unit #:
Reference:	Drawing #:

System UPC Product Code: 810175554235
 A-Coil UPC Product Code: 810175554068
 Outdoor Unit UPC Product Code: 810175554136



OUTDOOR UNIT SPECIFICATIONS

Compressor Type	Scroll	
Compressor Model	SKDC041N1ULB	
Compressor Capacity (W)	14200	
Compressor Input (W)	3300	
Compressor Rated Current RLA (A)	14.6	
Refrigerant Oil Type	Ester Oil VG46	
Refrigerant Oil Charge (mL)	1240	
Outdoor Noise Level (dBA)	60	
Outdoor Airflow (CFM)	2950	
Outdoor Fan Motor Qty.	1	
Outdoor Fan Motor Input (W)	200	
Outdoor Fan Motor RLA (A)	0.92	
Dimension (W×D×H)	inch	29.13 x 29.13 x 32.87
	mm	740 x 740 x 835
Package (W×D×H)	inch	30.32 x 30.32 x 34.01
	mm	770 x 770 x 865
Net/Gross Weight	lbs	176.0 / 187.0
	kg	80.0 / 85.0
RLA: Rated Load Amps	W: Watts	

EFFICIENCY RATINGS

Cooling	
SEER2	13.80
EER2	11.70

COOLING PERFORMANCE & OPERATING TEMPERATURE

Cooling (Btu/hr)		
Rated Capacity	46000	
System Power Input (W)	3930	
Rated Current (A)	17.80	
Ambient Temperature Range (Cooling Operation)		
Indoor Unit	°F	60°F ~ 90°F
	°C	16°C ~ 32°C
Outdoor Unit	°F	5°F ~ 131°F
	°C	-15°C ~ 55°C

ELECTRICAL SPECIFICATIONS

Indoor Power Supply	220-230V, 1Ph, 60Hz	
Outdoor Power Supply	208/230V, 1 Ph, 60Hz	
Voltage Range (V)	187 ~ 253	
Outdoor MCA (A)	27	
Outdoor MOP (A)	40	
MCA: Min. circuit amps (A)	MOP: Max. overcurrent protection (A)	

EVAPORATOR A-COIL SPECIFICATIONS

Dimension (W×D×H)	inch	21.02 x 21.02 x 27.80
	mm	534 x 534 x 706
Package (W×D×H)	inch	24.80 x 27.36 x 30.12
	mm	630 x 695 x 765
Net/Gross Weight	lbs	81.0 / 92.0
	kg	36.8 / 41.9

REFRIGERANT & PIPING SPECIFICATIONS

Throttle type (Indoor)	TXV for Cooling	
Refrigerant Type	R32	
Refrigerant Charge	oz	91.71
	kg	2.60
Additional Charge of Refrigerant	oz/ft	0.52
	g/m	48.0
Liquid Side	in	3/8"
	mm	9.53
Gas Side	in	3/4"
	mm	19.05
Max. Piping Length (Condenser Pre-Charge)	ft	24.6
	m	7.5
Max. Piping Length	ft	213
	m	64
Max. Height Difference	ft	98
	m	30
Drainage Water Pipe Diameter (O.D.)	in	3/4"
	mm	19.05 mm
Connection Method	Indoor Unit	Braze
	Outdoor Unit	Flare to Braze

EVAPORATOR A-COIL DIMENSIONS

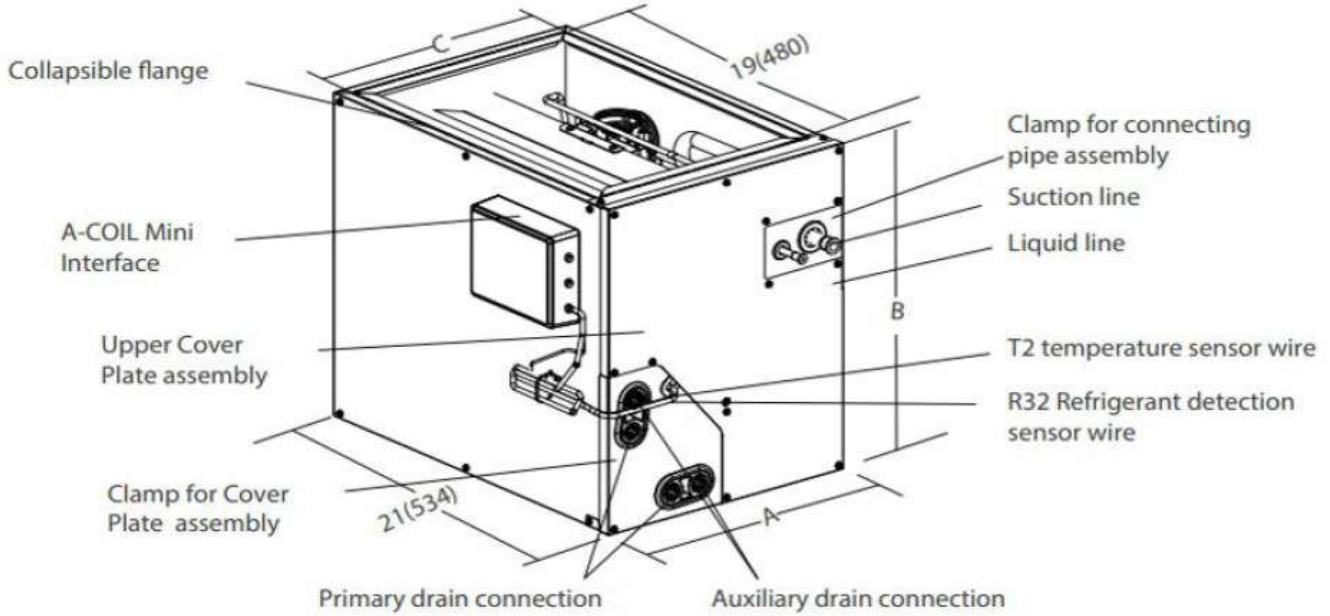

Model	18K/24K A-Coil 17.5"		30K/36K A-Coil 17.5"		30K/36K A-Coil 21"	
Dimensions	inch	mm	inch	mm	inch	mm
A	17-1/2	445	17-1/2	445	21	534
B	18	457	23-1/2	599	23-1/2	599
C	16-2/5	416	16-2/5	416	19-3/4	505
Model	48K/60K A-Coil 21"		48K/60K A-Coil 24.5"			
Dimensions	inch	mm	inch	mm		
A	21	534	24-1/2	622		
B	27-4/5	706	27-4/5	706		
C	19-3/4	505	23-2/5	594		

OUTDOOR UNIT DIMENSIONS

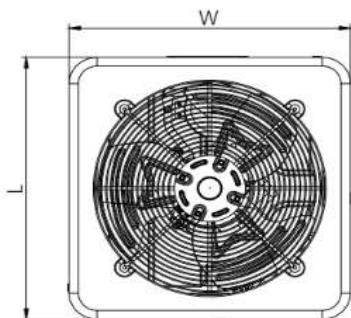
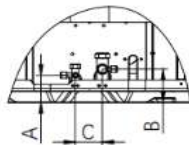
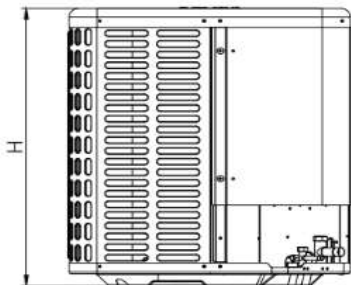

Dimensions		Model	18K/24K		30K/36K		42K/48K/60K	
			inch	mm	inch	mm	inch	mm
W	Model width		23-5/8	600	29-9/64	740	29-9/64	740
L	Model length		23-5/8	600	29-9/64	740	29-9/64	740
H	Model height		25	635	25	635	32-7/8	835
A	Liquid side valve height		2-31/64	63	2-31/64	63	2-31/64	63
B	Distance between two valves		3-1/32	77	3-1/32	77	3-1/32	77
C	Gas side valve height		2-9/32	58	2-9/32	58	2-9/32	58