

Job Name:	
Submitted By:	



<b>Submittal Sheet For:</b>	<b>CT009GLSILCFHG / YN009GLSI24RPG</b>
-----------------------------	--

Date \_\_\_\_\_  
 Ref. \_\_\_\_\_

**Ceiling Cassette Ductless 23SEER Inverter Heat Pump**

System Full Set Model: **CYT009GLSI24RL**

AHRI Reference Number: **217048758**

**Cooling Mode Performance**

Rated Cooling	9,500 BTU/hr
Ambient Range	5~131°F
SEER2 Rating	23.0 BTU/W·h
EER2 Rating	12.5 BTU/W·h

\* 100% Capacity @ Indoor DB 80°F / WB 67°F

**Heating Mode Performance**

Rated Heating	9,500 BTU/hr
Ambient Range	-13~86°F
HSPF2 IV (V)	10.5 (9.0) BTU/W·h
COP2 (47°F)	3.8 W/W

Heating (17°F) = 8,500 BTU / Heating (5°F) = 7,400 BTU / COP2 (5°F) = 1.95 W/W



Ceiling Cassette Indoor Unit



Outdoor Condensing Unit



User-Selected Installation Kit



Handheld Remote Controller

**Electrical Information**

	Cooling	Heating
Rated Input (W)	750	720
Rated Current (A)	3.3	3.1
Breaker Needed	15A (Double-Pole)	
Power Supply	208~230V, 60Hz, 1Ph	

**Piping and Refrigerant**

Liquid Line (OD)	1/4 in
Suction Line (OD)	3/8 in
Refrigerant Precharge	R-454b(Supports 10-50 ft.)
Max Length/Height Diff.	50 ft. / 33 ft.

This combination is Energy-Star certified.



**Interior Unit (Air Handler) Specifications**

Type	Heat Pump
Sound Level (dBA)	43 (Turbo)/ 40 (Hi)/ 33 (Med)/ 31 (Lo)/ 30 (Mute)
Auto Air Circulation	2-Way Louver (Up-Down + Left-Right)
Dimensions (WDH)	22-1/2 in x 22-1/2 in x 9-5/8 in
Weight (lbs)	32

**Exterior Unit (Condenser) Specifications**

Sound Level (dBA)	50
Recommended Room Size	250~350 Sq. ft.
Minimum Room Size	28 Sq. ft.
Compressor	Inverter-Driven Rotary
Dimensions (WDH)	31-7/8 in x 12 in x 21-5/8 in
Weight (lbs)	52.7

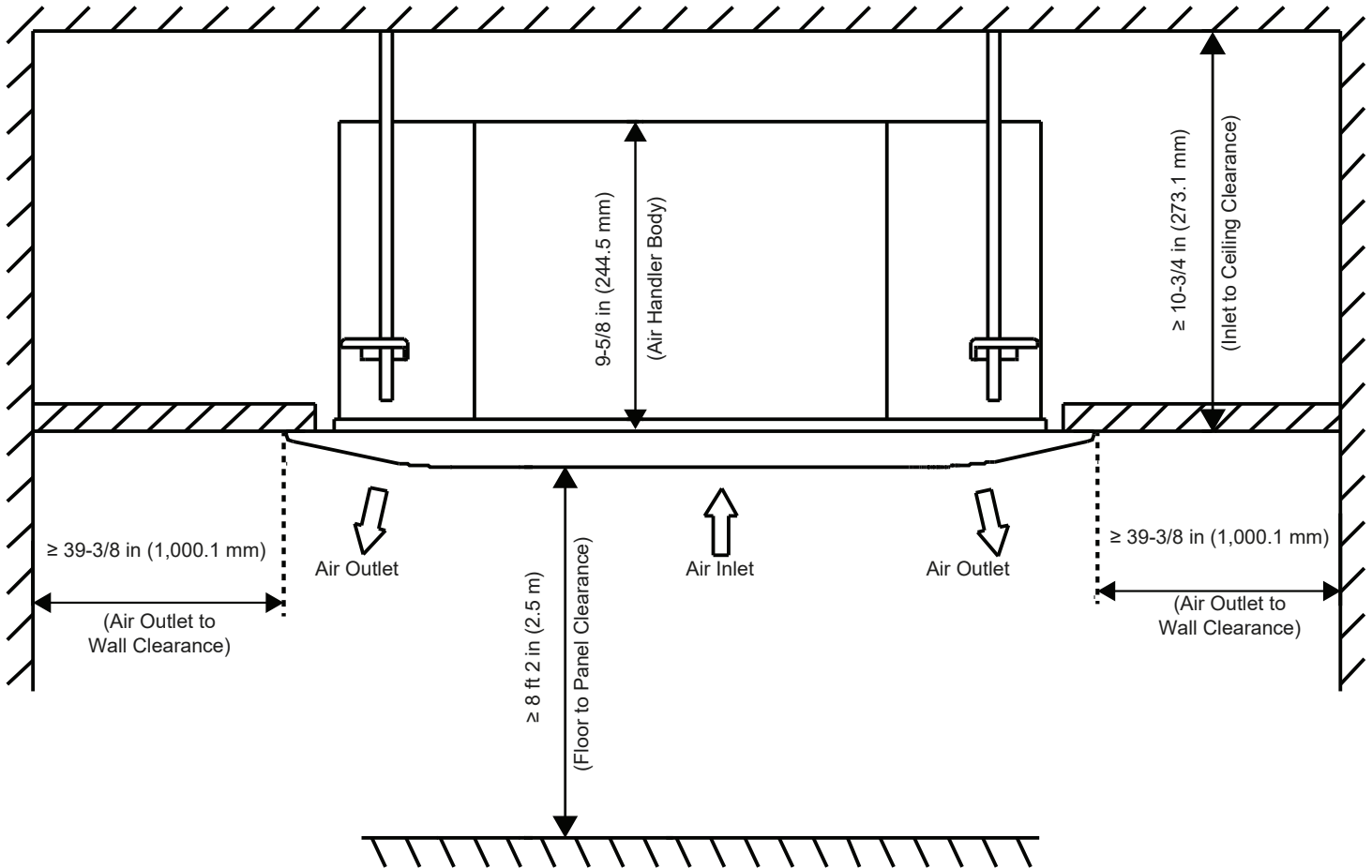
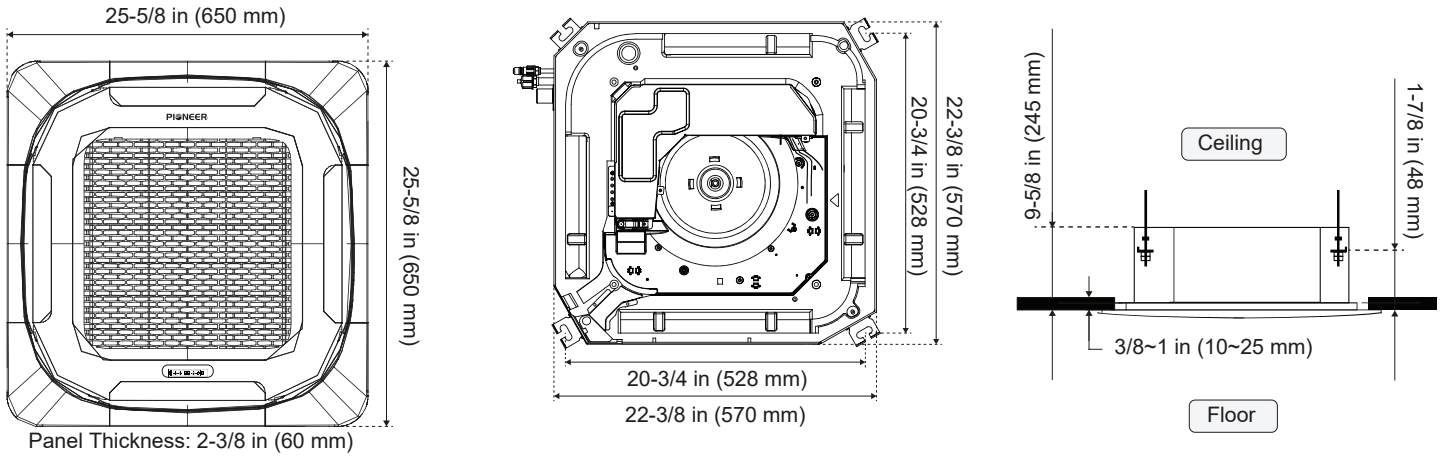

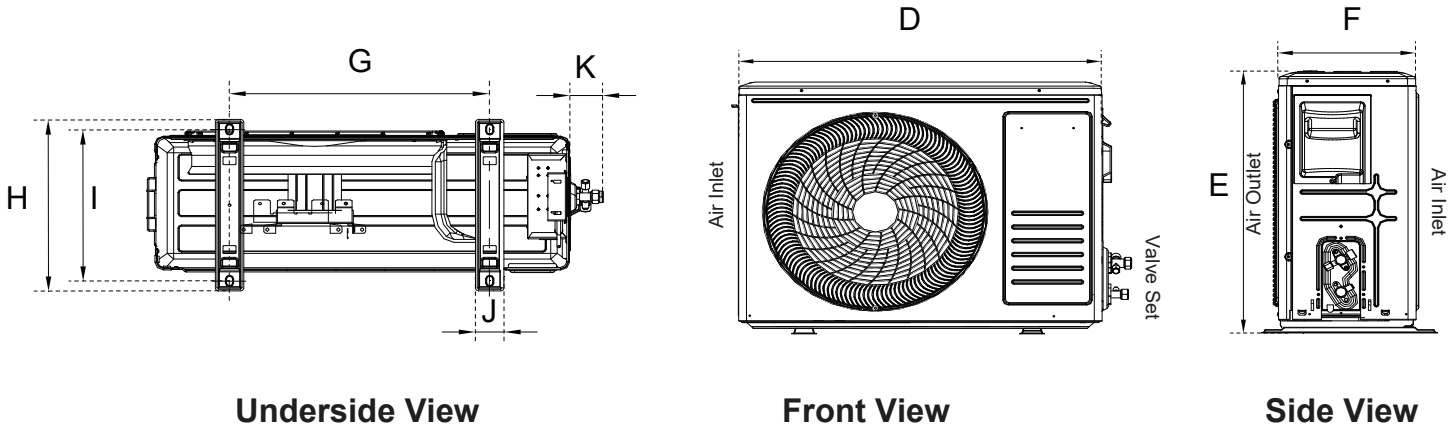

Model	D	E	F	G	H	I	J	K
YN009GLSI24RPG	29-1/8 in	21-3/4 in	10 in	17-1/8 in	12 in	11-1/4 in	1-7/8 in	2-1/4 in
	741 mm	551 mm	253 mm	434 mm	304.8 mm	285 mm	48 mm	58 mm

### Warranty Information and Length



Complete warranty details are available with the vendor or online at <https://www.pdhvac.com/support/warranty/>. This high quality system is eligible for up to 10 years limited warranty on the compressor, and 7 years on other internal parts. To qualify for this warranty, the system must be installed within 90 days by a registered technician. All other installations that are registered default to 5 years parts/compressor. Products unregistered qualify for only 1 year parts/compressor warranty.

### Outstanding Features

- LED Display
- Energy Saving
- Ultra-Thin Design
- Dual Drain Options
- Customizable Timer
- Eco-Friendly Refrigerant
- Whisper-Quiet Operation
- Power Loss Memory Recovery



### Available Accessories

Part Number	Description
IKT-LCVR4P-KIT	<i>Decorative PVC Line Cover Kit</i>
IKT-LNBR-1/4-3/8	<i>BendAid Flexible Easy Bender Kit</i>
BRK-FRM-C-2P	<i>Folding Mounting Bracket w/ Leveler</i>
IKT-UVL32UL-AG	<i>UVC Bacterial Disinfection Kit</i>
IKT-SURPRK-DV2	<i>Ultimate Surge and Power Protection</i>