

FTMA5

QuietComfort™ Fan Coil — Variable Speed Constant Airflow Motor— R-454B Refrigerant Sizes 24 – 60



Product Data



A230450

PREMIUM ENVIRONMENTALLY RESPONSIBLE FAN COIL

The FTMA5 is the premium air handler combining the proven technology of ICP fan coils with environmentally balanced R-454B refrigerant. The FTMA5 achieves an operational advantage when the variable speed ECM (Electronically Commutated Motor) is combined with a heat pump or air conditioner with R-454B refrigerant.

With attention to quiet, efficient, and comfortable operation, ICP has developed a new benchmark for superior indoor comfort and control.

ICP heat pump and air conditioning systems feature R-454B refrigerant, the chlorine-free refrigerant that is the future for the residential heating and cooling industry. The FTMA5 using R-454B refrigerant maximizes performance for environmentally balanced systems. In addition to environmental safety, these systems are 30 to 40% more efficient than standard heating and cooling systems, thereby combining excellence in efficiency and environmental responsibility.

The FTMA5 provides these benefits due to ICP's command of ECM technology. These motors are extremely efficient at all speeds, and enable the FTMA5 to operate at the correct speed to deliver airflow precisely, ensuring proper performance across a wide range of duct static pressures. This adaptive efficiency also makes installation quality easier to achieve for today's demanding homeowner.

ICP command of ECM technology may be most evident in the comfort advantages that ECM can deliver. Operation set up steps on the Easy Select™ Board provide the installing technician with alternatives to maximize comfort and efficiency. For true indoor comfort, the homeowner can achieve command of both temperature and humidity in cooling and heating modes.

Another feature which sets the FTMA5 apart is the factory-installed TXV, which enhances efficiency and provides compressor protecting operation at all recommended conditions. Grooved tubing, louvered

aluminum fins, and the large face areas of the FTMA5 refrigerant coils also provide superior efficiency, for high SEER and HSPF performance. ICP leads the way in condensate control, a hallmark of these multipoise fan coils. All of these featured components are protected within a rugged, pre-painted metal cabinet lined with super thick, high density insulation. For neat, high quality installations the unit exterior features sweat refrigerant connections for simple leak free performance, and multiple electrical entry for both high and low voltage service.

Assembled at the factory compliant with low leak requirements of less than 2% cabinet leakage rate at 1 inches W.C. and 1.4% cabinet leakage rate at 0.5 inches W.C. when tested in accordance with ASHRAE 193 standard.

FEATURES

Environmentally Balanced Refrigerant Technology

- R-454B, chlorine-free, non-ozone depleting refrigerant
- Refrigerant leak detection dissipation system for added safety
- Thermostatic Expansion Valve (TXV) designed to maximize performance with R-454B refrigerant

Energy Efficient Operation

- Variable Speed Constant Airflow ECM (Electronically Commutating Motor) operates efficiently at all speeds
- Maximizes efficiency of heating and cooling systems
- Ultra low power consumption during fan only operation

Indoor Weather Control

- Warm, comfortable heating air temperatures
- Unmatched humidity control, especially with thermostat with relative humidity controls

Airflow and Sound Technology

- Diffuser air discharge section for high airflow efficiency and quiet, smooth operation
- High duct static capability
- Design meets stringent regulations for cabinet air leakage of less than 2% cabinet leakage rate at 1 inches W.C. and 1.4% cabinet leakage rate at 0.5 inches W.C. when tested in accordance with ASHRAE 193 standard.

Condensate Control and Disposal Technology

- Minimal standing waterless microbial growth for improved IAQ and reduced condensate line clogging and related condensate leakage
- Condensate fittings relocated away from turbulent airflow patterns at the blower entrance for improved condensate control performance
- Overflow feature for slope coil units allows condensate to exit the unit without damage to product under clogged primary and secondary line conditions
- Tested for condensate disposal at conditions much more severe than those required by AHRI
- Primary and secondary drain connections to comply with HUD
- All pans constructed of an injection molded glass-filled polycarbonate engineered resin material, with brass drain connections.
- High density, super thick cabinetry insulation with vapor barrier
- Pre-painted galvanized sheet metal cabinet

Heat Transfer Technology

- Grooved tubing
- Lanced sine wave aluminum fins
- Discreet refined counter-flow refrigerant circuitry
- Bi-flow hard shut-off TXV metering device with mechanical fittings

Quality Assisting, Ease of Installation and Service Features

- All units multipoise
- Provision made for suspending from roof or ceiling joints
- Modular cabinet on 36 thru 60 size units
- Sweat connections for leak free service
- Multiple electrical entry for application flexibility (high and low voltage)
- Low voltage terminal strip, to safely hold connections within the cabinet
- Cabinet construction features innovations designed to prevent cabinet sweating

Controls and Electrical Features

- Easy Select™ Board to maximize comfort, efficiency, and safe heater airflow operation

- Easy plug connection provided for quick installation of accessory heater packages
- 40VA 208/230V transformer
- Replaceable 5A blade-type auto fuse protects against transformer secondary short

Filter Features

- Factory supplied filter
- New standard sized filter rack fits most common size replacement filters

WARRANTY

- 10-year No Hassle Replacement limited warranty
 - Default 5-year parts limited warranty
 - 10-year parts limited warranty with timely registration *.
 Equipment must be registered within 90 days of original installation, except in jurisdictions where warranty benefits cannot be conditioned on registration.

* Applies to original purchaser/homeowner and not available to subsequent owners, except in jurisdictions where laws dictate otherwise.

See Warranty certificate for complete details and restrictions.

Table 1 – Model Nomenclature

	1	2	3	4	5	6	7	8	9	10	11	12
	F	T	M	A	5	X	3	6	L	0	B	A
Product F = Fan Coil											Series Code	
Type T = Quiet Comfort Series, Variable Speed Constant Airflow (VCA) Motor											Cabinet Width A = 17" B = 21" C = 24"	
Position M = Multipoise											Coil Type L = Aluminum	
Major Series												
Refrigerant 5 = R-454B												
Metering Device X = Singular, TXV B = Modular, TXV												
											Capacity 24 = 24,000 36 = 36,000 48 = 48,000 60 = 60,000	



Use of the AHRI Certified TM Mark indicates a manufacturer's participation in the program. For verification of certification for individual products, go to www.ahridirectory.org.



ISO 9001
CERTIFIED SYSTEM



Table 2 – Models Available

2 Ton	3 Ton	4 Ton	5 Ton
FTMA5X24	FTMA5B36	FTMA5B48	FTMA5B60

Table 3 – Specifications

EVAPORATOR COIL				
	2 Ton	3 Ton	4 Ton	5 Ton
Face Area (sq ft)	3.46		5.93	7.42
Configuration	A	Slope	A	
Metering Device R-454B	TXV			
Refrigerant Sweat Liquid Line Connection, in (mm)	3/8 (9.5) ID			
Refrigerant Sweat Suction Line Connection, in (mm)	3/4 (19.1) ID		7/8 (22.2) ID	
TXV Replacement P/N	EA66YP004	EA66YP002	EA66YP005	EA66YP006
Rows/Fins per Inch	3 / 14.5			
BLOWER & MOTOR				
Air Discharge	Upflow, Downflow, Horizontal			
CFM (Nominal Clg/Htg)	525	700	875	1050
	700	875	1050	1225
	875	1050	1225	1400
	1050	1225	1400	1750
Motor HP (ECM)	1/2		3/4	
FILTERS				
The fan coil filter rack can accommodate most common size filters.				
L x W in, (mm)	16 x 20 (406 x 508)	20 x 20 (508 x 508)		24 x 20 (610 x 508)
CABINET CONFIGURATION OPTIONS				
	Singular (1-piece)		Modular (2-piece)	

DIMENSIONS (cont.)

- NOTES:
 1. CONDENSATE PAN DRAIN CAPS NOT SHOWN FOR CLARITY.
 2. ALL DIMENSIONS ARE IN "INCHES" UNLESS NOTED.

SLOPE COIL

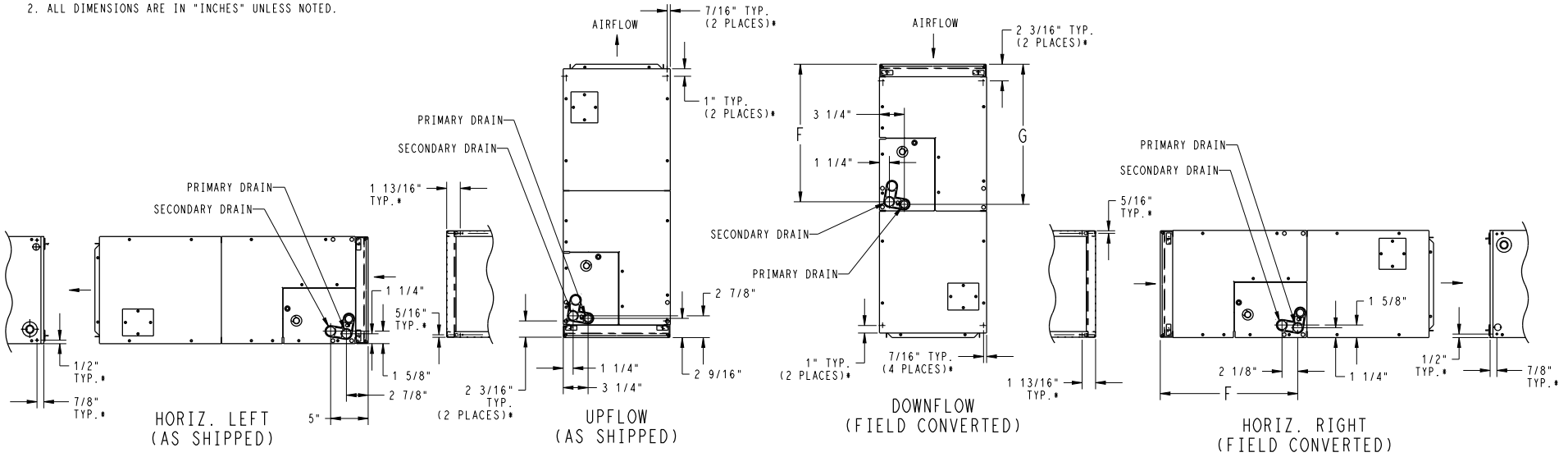

* HORIZONTAL MOUNT LOCATIONS - DIMPLES PROVIDED IN TOP PANEL, AND BACK OF CABINET. IN CABINET BOTTOM, HOLES PROVIDED .136" DIA. HORIZONTAL HANGING HARDWARE TO BE FIELD SUPPLIED.

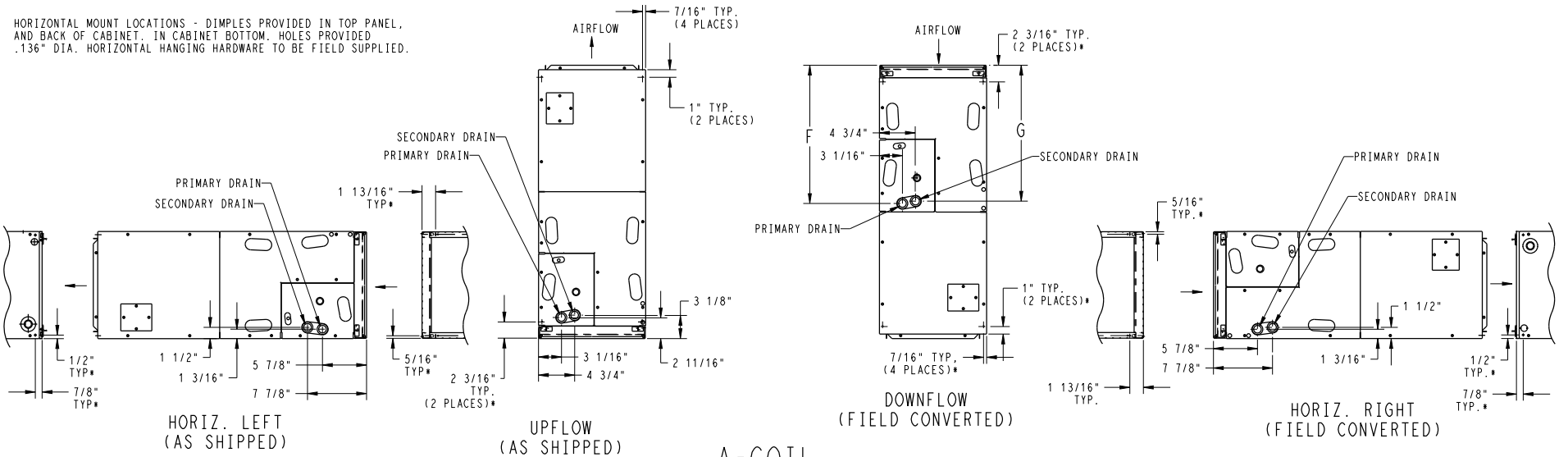

A-COIL

Fig. 2 – Dimensions, sheet 2

Manufacturer reserves the right to change, at any time, specifications and designs without notice and without obligations.

DIMENSIONS (cont.)

Manufacturer reserves the right to change, at any time, specifications and designs without notice and without obligations.

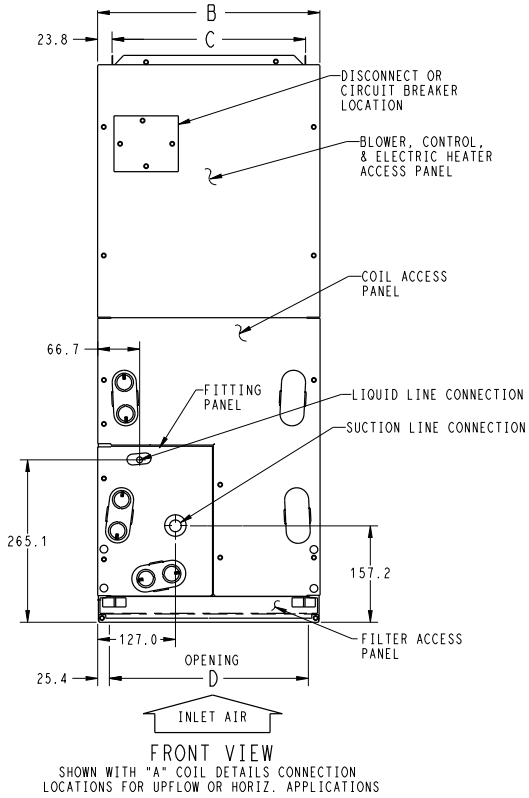
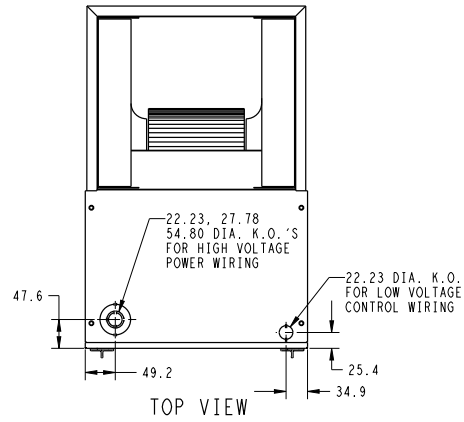

UNIT CONNECTION SIZES

SUCTION: 24 & 36 - 19.05 I.D. SWEAT
48 & 60 - 22.23 I.D. SWEAT

LIQUID: 9.53 I.D. SWEAT

CONDENSATE: 19.0 FPT

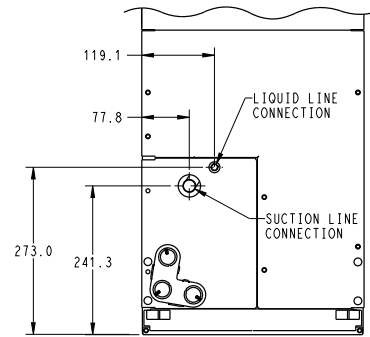

NOTE: ALLOW 533.4 FROM FRONT
FOR SERVICE

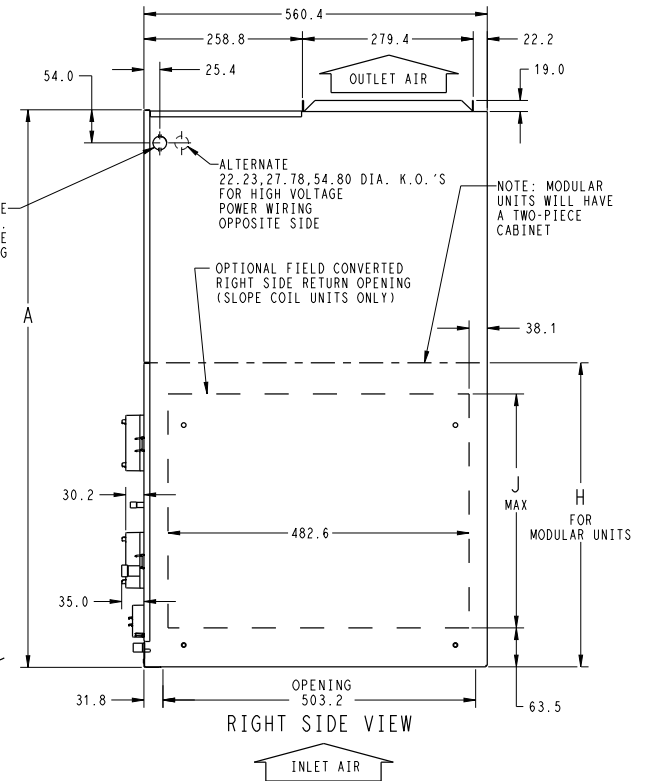
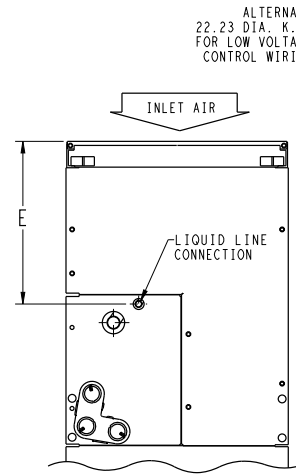

UNIT	SERIES	ELECTRICAL CHARACTERISTICS				A	B	C	D	E	F	G	H	J	COIL CONFIGURATION		SHIPPING WT (Kgs)
		SLOPE	"A"	SLOPE	"A"												
FTMA5X24	01	X	*			1084.3	447.7	400.0	396.9	273.0	471.5	463.6	-	-	-	X	56.3
FTMA5B36	01	X	*			1357.3	536.6	489.0	485.8	487.4	684.2	698.5	719.1	482.6	X	-	66.3
FTMA5B48	01	X	*			1357.3	536.6	489.0	485.8	495.3	692.2	684.2	719.1	-	-	X	76.3
FTMA5B60	01	X	*			1503.4	627.1	577.8	576.3	641.4	836.6	828.7	865.2	-	-	X	92.2

208/230-1-60
208/230-3-60

X=YES
O=NO
*YES, DUE TO AVAILABLE FIELD
INSTALLED HEATERS.

- NOTE:
- SERIES DESIGNATION IS THE 13TH & 14TH POSITIONS OF UNIT PRODUCT NUMBER.
 - ALL DIMENSIONS ARE IN "MM" UNLESS NOTED.

Fig. 3 – Dimensions, sheet 3

PERFORMANCE DATA

Table 4 – Airflow Delivery Chart – (CFM) in Cooling Mode*

OPERATING MODE										
UNIT SIZE	OUTDOOR UNIT CAPACITY	SINGLE—SPEED APPLICATION		TWO—SPEED APPLICATION				FAN ONLY		
		Nominal A/C Cooling	A/C Cooling Dehum	High Speed		Low Speed		Lo	Med	High
				Nominal A/C Cool	A/C Cool Dehum	Nominal A/C Cool	A/C Cool Dehum			
24	018	525	420	—	—	—	—	350	420	525
	024	700	560	700	560	560	450	350	560	700
	030	875	700	—	—	—	—	435	700	875
	036	1050	840	1050	840	840	670	525	840	1050
36	024	700	560	700	560	560	450	350	560	700
	030	875	700	—	—	—	—	435	700	875
	036	1050	840	1050	840	840	670	525	840	1050
	042	1225	980	—	—	—	—	610	980	1225
48	030	875	700	—	—	—	—	435	700	875
	036	1050	840	1050	840	840	670	525	840	1050
	042	1225	980	—	—	—	—	610	980	1225
	048	1400	1120	1400	1120	1120	895	700	1120	1400
60	036	1050	840	1050	840	840	670	525	840	1050
	042	1225	980	—	—	—	—	610	980	1225
	048	1400	1120	1400	1120	1120	895	700	1120	1400
	060	1750	1400	1750	1400	1400	1120	875	1400	1750

NOTES:

- * Consult ARI ratings before matching outdoor unit with fan coil.
- 1. The above airflows result with the AC, HP CFM ADJUST select jumper set on NOM.
- 2. Air flow can be adjusted +15% or -10% by selecting HI or LO respectively for all modes except fan only.
- 3. Dry coil at 230 volts and with 10kW heater and filter installed.
- 4. Airflows shown are at standard air conditions.

Table 5 – Cooling Airflow Delivery (CFM) when pairing with D5CU* (2-Speed ODU)

OPERATING MODE								
UNIT SIZE	OUTDOOR UNIT CAPACITY	TWO—SPEED APPLICATION				FAN ONLY		
		High Speed		Low Speed		Lo	Med	High
		Nominal A/C Cooling	A/C Cooling Dehumidity	Nominal A/C Cooling	A/C Cooling Dehumidity			
24	18	525	420	420	350	350	420	525
	24	700	560	560	450	350	560	700
	30	875	700	700	560	435	700	875
	36	1050	840	840	670	525	840	1050
36	24	700	560	560	450	350	560	700
	30	875	700	700	560	435	700	875
	36	1050	840	840	670	525	840	1050
	42	1225	980	980	450	610	980	1225
48	30	875	700	700	560	434	700	875
	36	1050	840	840	670	525	840	1050
	42	1225	980	980	785	610	980	1225
	48	1400	1120	1120	895	700	1120	1400
60	36	1050	840	840	670	525	840	1050
	42	1225	980	980	785	610	980	1225
	48	1400	1120	1120	895	700	1120	1400
	60	1750	1400	1400	1120	875	1400	1750

Table 6 – Airflow Delivery Chart – (CFM) in Heat Pump Only Heating Mode

OPERATING MODE										
UNIT SIZE	OUTDOOR UNIT CAPACITY	SINGLE—SPEED APPLICATION		TWO—SPEED APPLICATION				FAN ONLY		
		Heat Pump Comfort	Heat Pump Efficiency	High Speed		Low Speed		Lo	Med	High
				Heat Pump Comfort	Heat Pump Efficiency	Heat Pump Comfort	Heat Pump Efficiency			
24	018	470	525	—	—	—	—	350	420	525
	024	630	700	630	700	505	560	350	560	700
	030	785	875	—	—	—	—	435	700	875
	036	945	1050	945	1050	755	840	525	840	1050
36	024	630	700	630	700	505	560	350	560	700
	030	785	875	—	—	—	—	435	700	875
	036	945	1050	945	1050	755	840	525	840	1050
	042	1100	1225	—	—	—	—	610	980	1225
48	030	785	875	—	—	—	—	435	700	875
	036	945	1050	945	1050	755	840	525	840	1050
	042	1100	1225	—	—	—	—	610	980	1225
	048	1260	1400	1260	1400	1010	1120	700	1120	1400
60	036	945	1050	945	1050	755	840	525	840	1050
	042	1100	1225	—	—	—	—	610	980	1225
	048	1260	1400	1260	1400	1010	1120	700	1120	1400
	060	1575	1750	1575	1750	1260	1400	875	1400	1750

NOTES:

1. The above airflows result with the AC, HP CFM ADJUST select jumper set on NOM.
2. Air flow can be adjusted +15% or -10% by selecting HI or LO respectively for all modes except fan only.
3. Dry coil at 230 volts and with 10kW heater and filter installed.
4. Airflows shown are at standard air conditions.

Table 7 – Airflow Delivery Chart (CFM) — Electric Heating Modes

FAN UNIT SIZE	OUTDOOR UNIT CAPACITY BTUH	ELECTRIC HEATER kW RANGE											
		0-5			0-10			0-15			0-20		
		Lo	Nom	High	Lo	Nom	High	Lo	Nom	High	Lo	Nom	High
24	18,000	700	700	805	750	750	863	—	—	—	—	—	-
	24,000	700	700	805	750	750	863	1050	1050	1208	—	—	-
	30,000	875	875	1006	875	875	1006	1050	1050	1208	1200	1200	1380
	36,000	1050	1050	1208	1050	1050	1208	1050	1050	1208	1200	1200	1380
36	24,000	700	700	805	750	750	863	1050	1050	1208	1225	—	-
	30,000	875	875	1006	875	875	1006	1050	1050	1208	1225	—	-
	36,000	1050	1050	1208	1050	1050	1208	1050	1050	1208	1225	1225	1409
	42,000	1225	1225	1409	1225	1225	1409	1225	1225	1409	1225	1225	1409
FAN UNIT SIZE	OUTDOOR UNIT CAPACITY BTUH	ELECTRIC HEATER kW RANGE											
		0-10			0-15			0-20			0-30		
		Lo	Nom	High	Lo	Nom	High	Lo	Nom	High	Lo	Nom	High
48	30,000	1000	1000	1150	1200	1200	1380	—	—	—	—	—	—
	36,000	1100	1100	1265	1200	1200	1380	1300	1300	1495	—	—	—
	42,000	1225	1225	1409	1225	1225	1409	1350	1350	1553	—	—	—
	48,000	1400	1400	1610	1400	1400	1610	1400	1400	1610	1500	1500	1725
60	36,000	1200	1200	1380	1250	1250	1438	1350	1350	1553	—	—	—
	42,000	1225	1225	1409	1300	1300	1495	1350	1350	1553	—	—	—
	48,000	1400	1400	1610	14000	14000	1610	1400	1400	1610	1750	1750	2013
	60,000	1750	1750	2013	1750	1750	2013	1750	1750	2013	1750	1750	2013

NOTE: Lo, NOM, and HI refer to AC, HP CFM ADJUST selection.

—Airflow not recommended for heater/system size.

PERFORMANCE DATA (cont)

Table 8 – Minimum CFM for Electric Heater Application

FAN COIL UNIT SIZE	HEAT PUMP UNIT SIZE	CFM				
		HEATER SIZE kW				
		5	8, 9, 10	12, 15	18, 20	24, 30
24	018	700	750	—	—	—
	024	700	750	1050	—	—
	030	875	875	1050	1200	—
	036	1050	1050	1050	1200	—
36	024	700	700	1050	—	—
	030	875	875	1050	—	—
	036	1050	1050	1050	1225	—
	042	1225	1225	1225	1225	—
48	018	1000	1000	1120	—	—
	036	1100	1100	1200	1300	—
	042	1225	1225	1225	1350	—
	048	1400	1400	1400	1400	1500
60	018	1200	1200	1250	1350	—
	042	1225	1225	1300	1350	—
	048	1400	1400	1400	1400	1750
	060	1750	1750	1750	1750	1750

NOTES:

1. These airflows are minimum acceptable airflows as UL listed. Actual airflow delivered will be per airflow delivery chart for Electric Heating Modes.

PERFORMANCE DATA (cont)

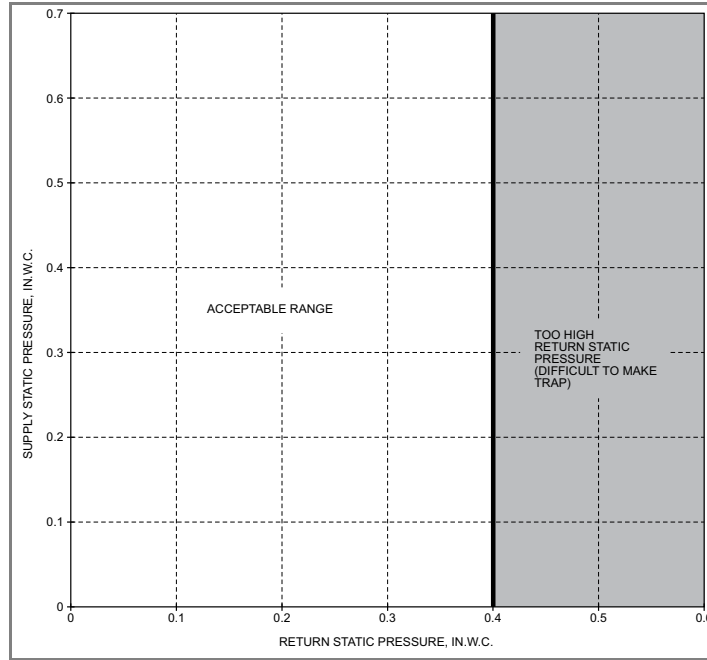

A02296

Acceptable Duct Conditions

For satisfactory operation (specifically making dry secondary trap), subject fan coils must be installed with duct systems which fall within the “Acceptable Range” illustrated above.

The airflow performance charts for the fan coil depict nominal airflow delivery for heating and cooling mode operation versus duct system static pressure drop. Cooling mode operation is shown as solid vertical lines for all 4 system size selections. Heating mode operation for the 4 system size selections are shown as dashed vertical lines.

The dotted curved lines are static pressure drop characteristics for several fixed-duct systems. These lines can be used to predict the system static pressure drop at any airflow given the actual drop at 1 known point.

For example, a duct system is designed for 0.15 in. water column (in. w.c.) drop at 1200 CFM. The FV4CNF005 operating at nominal cooling airflow would deliver 1050 CFM with a duct system drop of 0.11 in. w.c.. (See point 1 in the Airflow Performance/Static Pressure figure below.) On the same duct system, the FV4CNF005 operating at nominal heating airflow would deliver 945 CFM with a duct system drop of 0.09 in. w.c. (See point 2.)

This example is but one of many possible duct system designs. The FV4CNF005 will deliver the above airflows against much higher static pressures.

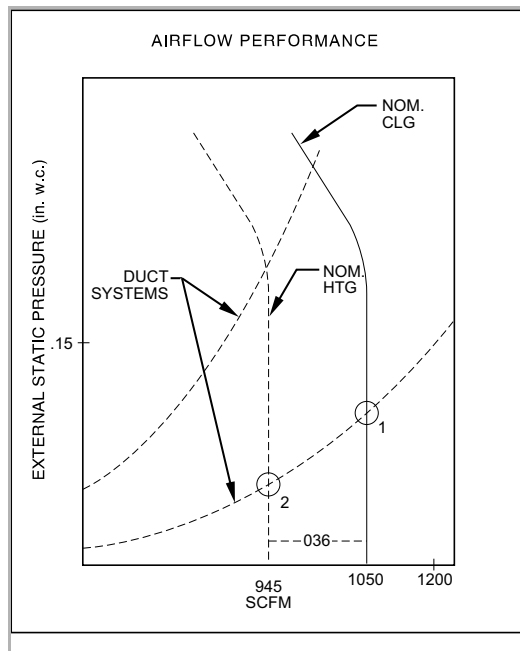

A09339

PERFORMANCE DATA (cont)

Airflow Performance, 24 size

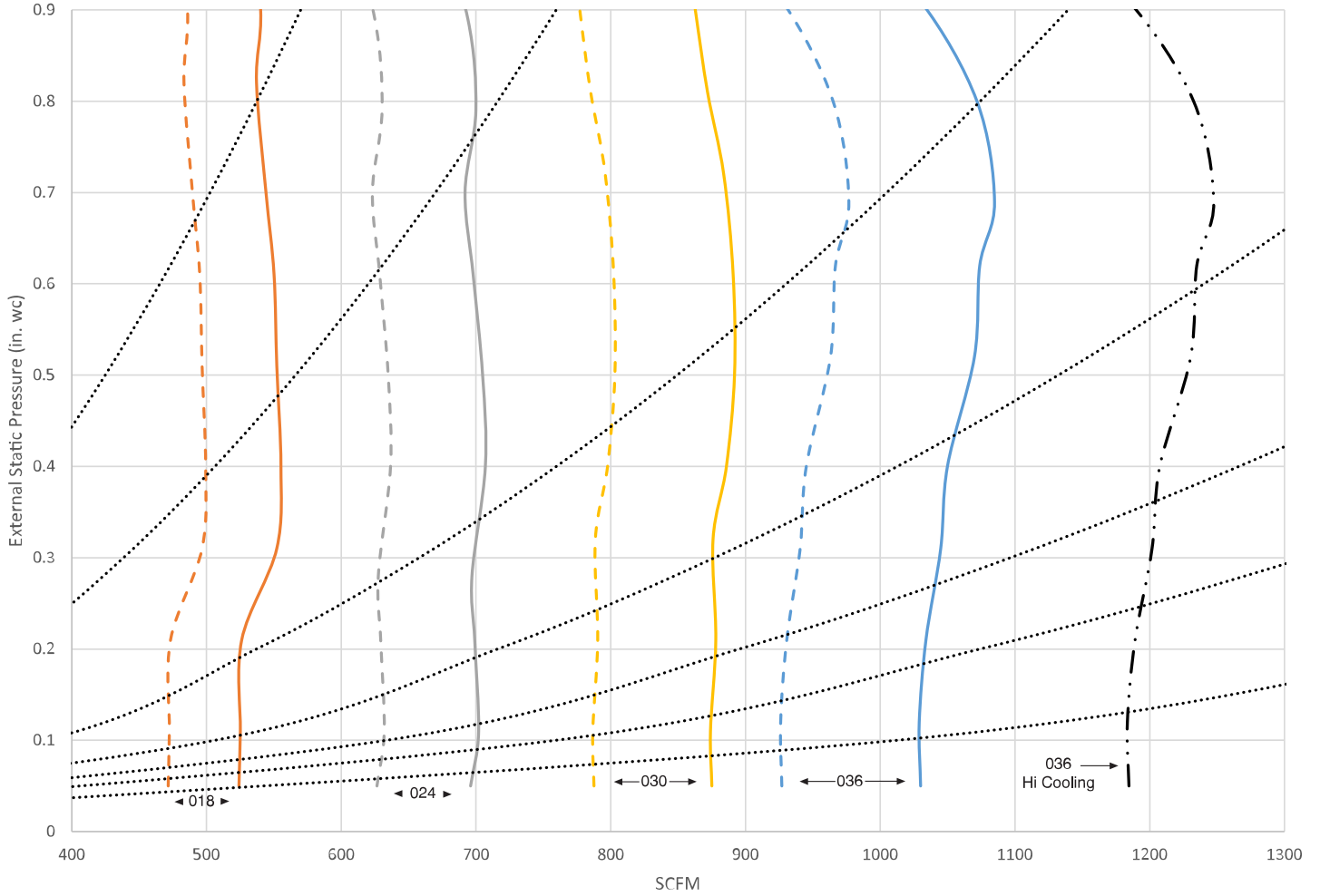

A230434

2 Ton

- Nominal Cooling and Heat Pump Efficiency airflow for each size selection. Airflow can be adjusted +15% to -10%.
- - - Nominal Heat Pump Comfort airflow for each size selection. Airflow can be adjusted +15% to -10%.
- · · · Maximum cooling airflow for largest size selection. Adjusted +15% from nominal.
- · · · Fixed Duct Systems (See description under Acceptable Duct Conditions.)

PERFORMANCE DATA (cont)

Airflow Performance, 36 size

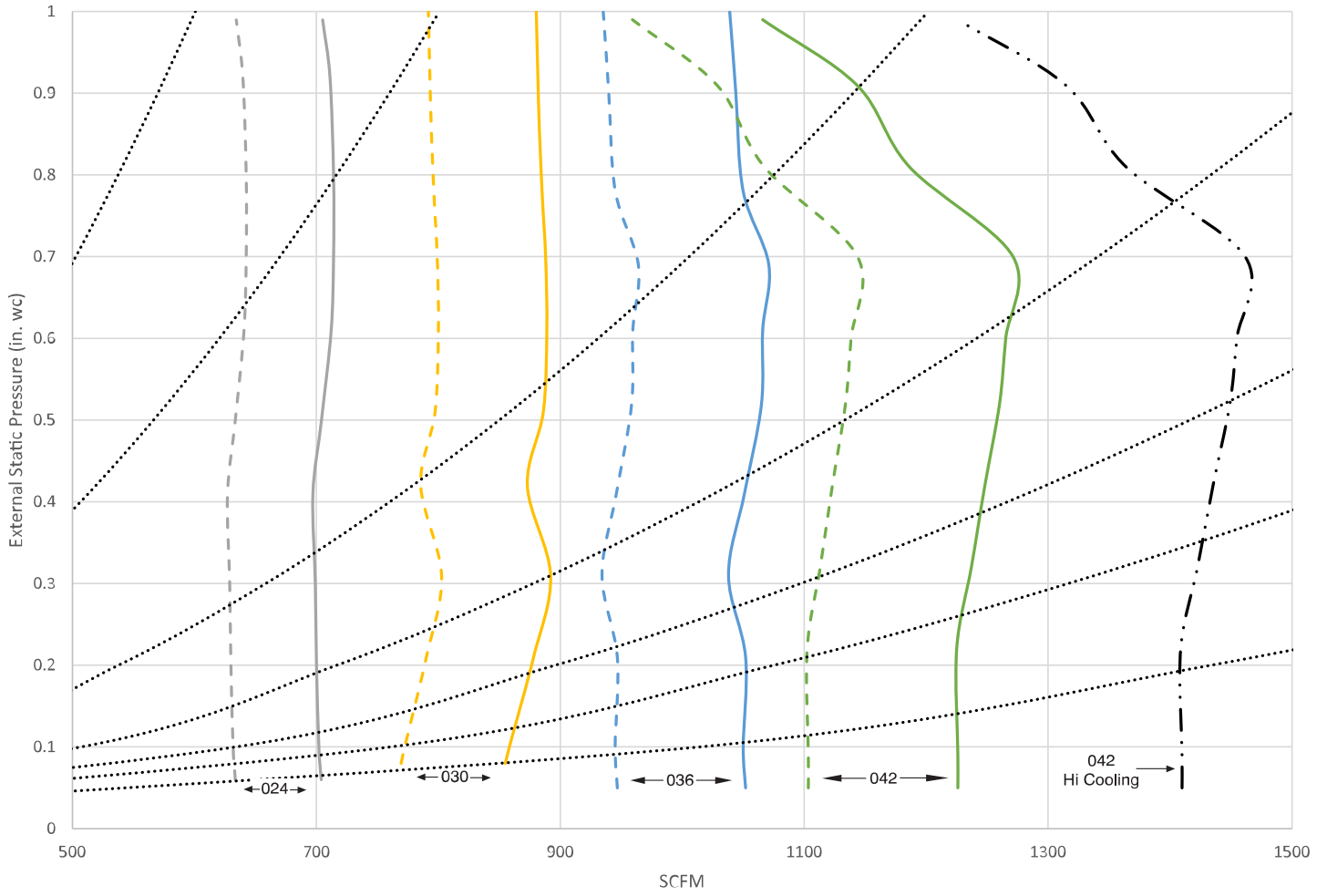

A230435

3 Ton

- Nominal Cooling and Heat Pump Efficiency airflow for each size selection. Airflow can be adjusted +15% to -10%.
- - - Nominal Heat Pump Comfort airflow for each size selection. Airflow can be adjusted +15% to -10%.
- · · · Maximum cooling airflow for largest size selection. Adjusted +15% from nominal.
- · · · Fixed Duct Systems (See description under Acceptable Duct Conditions.)

PERFORMANCE DATA (cont)

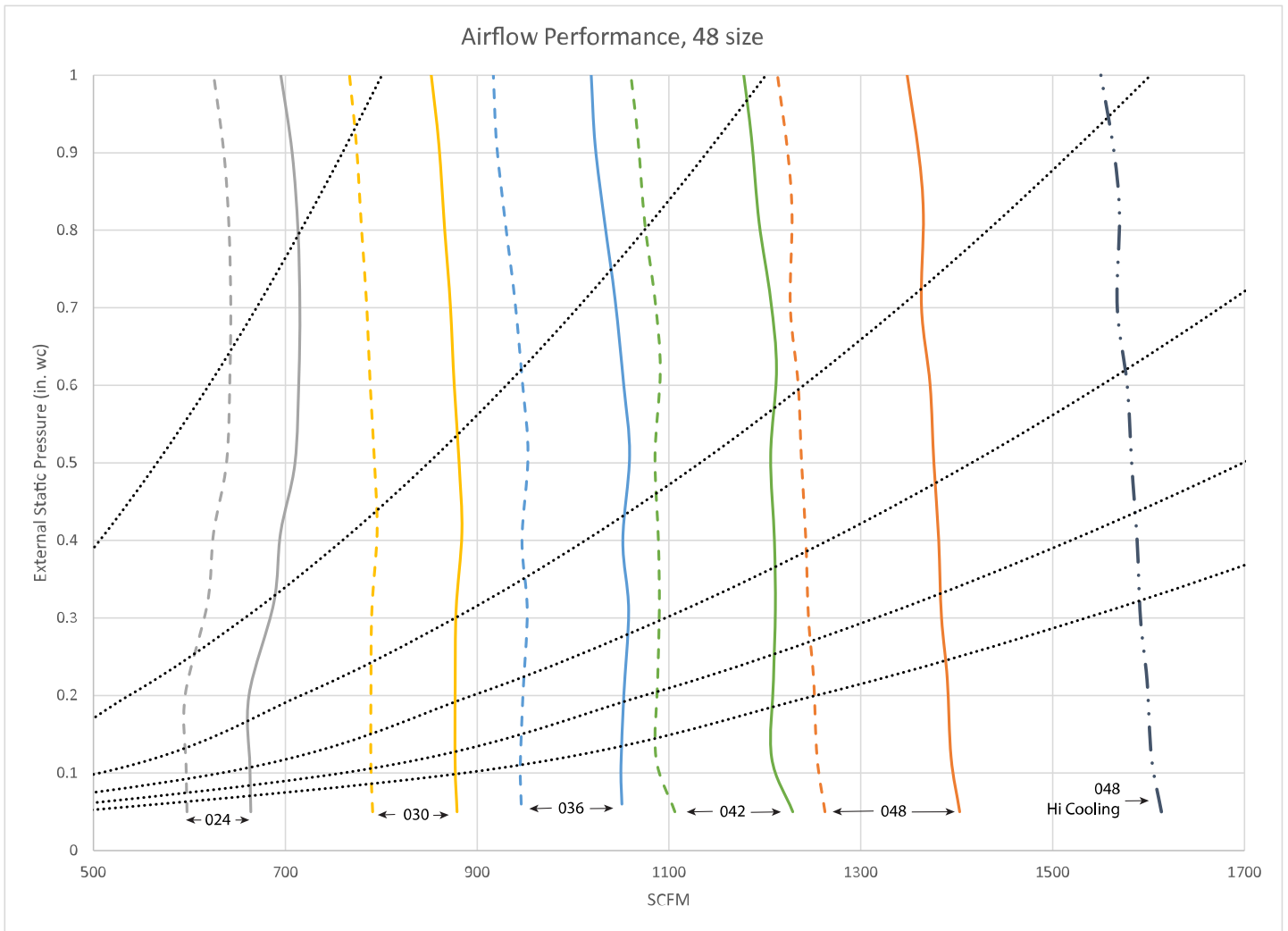

A230436

4 Ton

- Nominal Cooling and Heat Pump Efficiency airflow for each size selection. Airflow can be adjusted +15% to -10%.
- Nominal Heat Pump Comfort airflow for each size selection. Airflow can be adjusted +15% to -10%.
- · · · Maximum cooling airflow for largest size selection. Adjusted +15% from nominal.
- · - · Fixed Duct Systems (See description under Acceptable Duct Conditions.)

PERFORMANCE DATA (cont)

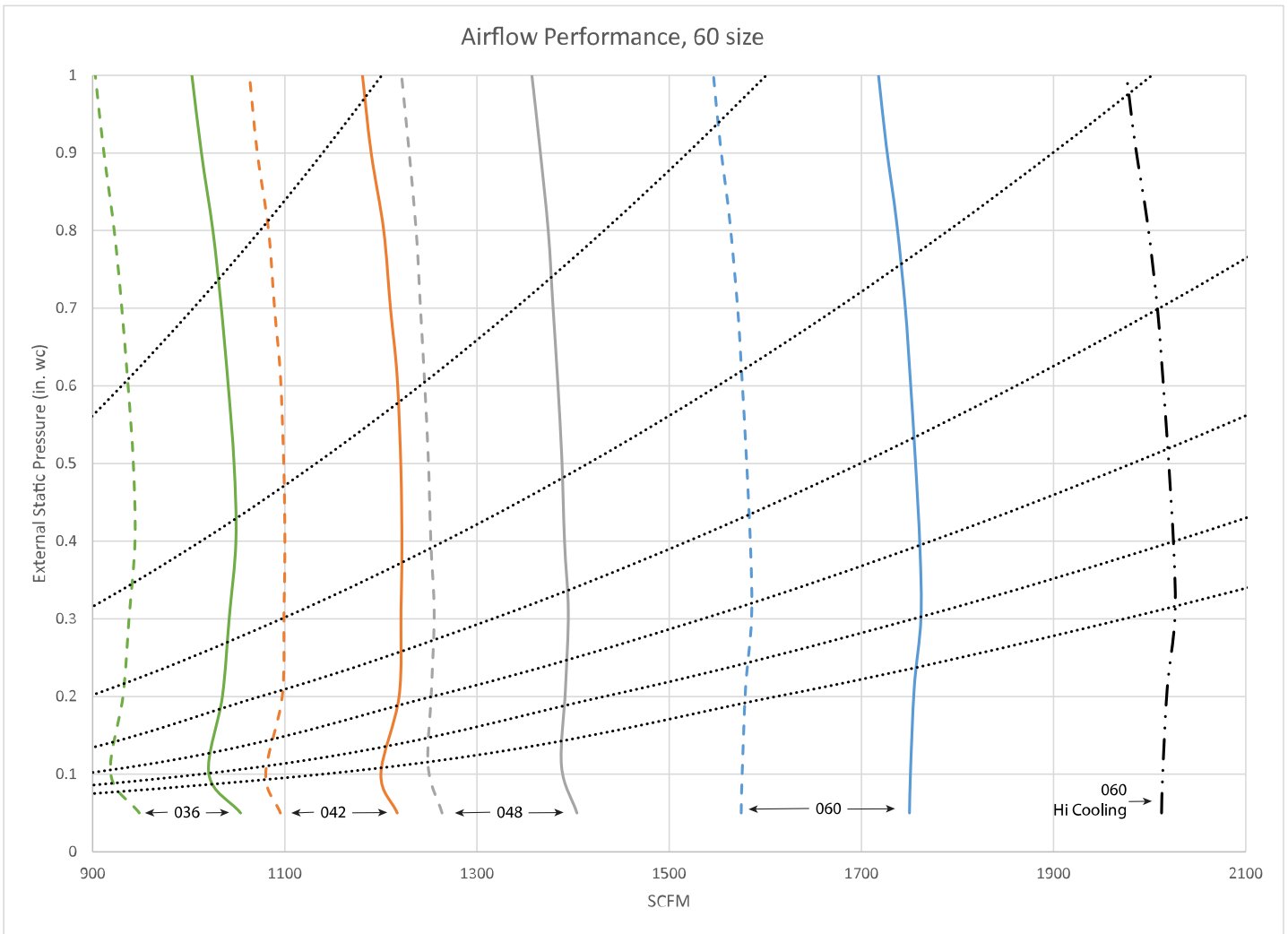

A230437

5 Ton

- Nominal Cooling and Heat Pump Efficiency airflow for each size selection. Airflow can be adjusted +15% to -10%.
- - - Nominal Heat Pump Comfort airflow for each size selection. Airflow can be adjusted +15% to -10%.
- · · · Maximum cooling airflow for largest size selection. Adjusted +15% from nominal.
- · · · Fixed Duct Systems (See description under Acceptable Duct Conditions.)

PERFORMANCE DATA (cont)

Table 9 – Cooling Capacities (MBtuh)

INDOOR COIL AIR		SATURATED TEMPERATURE LEAVING EVAPORATOR (deg F)														
		35			40			45			50			55		
CFM	EWB	TC	SHC	BF	TC	SHC	BF	TC	SHC	BF	TC	SHC	BF	TC	SHC	BF
SIZE 24																
525	72	37.43	19.02	0.00	34.00	17.19	0.00	30.10	15.23	0.00	25.65	13.15	0.00	20.64	10.99	0.00
	67	30.69	19.43	0.00	27.12	17.47	0.00	23.06	15.40	0.00	18.59	13.27	0.00	13.61	11.08	0.00
	62	24.56	19.70	0.00	20.93	17.68	0.00	16.97	15.60	0.01	12.99	12.89	0.02	10.73	10.73	0.18
700	72	46.22	23.43	0.00	42.10	21.33	0.00	37.38	19.05	0.00	31.94	16.60	0.00	25.66	13.94	0.00
	67	38.17	24.40	0.01	33.83	22.11	0.01	28.81	19.63	0.00	23.12	16.95	0.01	16.96	14.30	0.01
	62	30.70	25.11	0.01	26.21	22.68	0.01	21.31	20.14	0.01	16.75	16.75	0.05	13.97	13.97	0.20
875	72	53.39	27.09	0.00	48.70	24.80	0.00	43.30	22.29	0.00	37.16	19.57	0.01	29.96	16.59	0.01
	67	44.26	28.66	0.01	39.35	26.15	0.01	33.65	23.41	0.01	27.11	20.38	0.02	19.88	17.29	0.02
	62	35.90	29.97	0.02	30.79	27.25	0.02	25.20	24.36	0.03	20.34	20.34	0.08	16.99	16.99	0.23
1050	72	59.25	30.19	0.00	54.13	27.79	0.00	48.25	25.09	0.01	41.43	22.16	0.02	33.60	18.95	0.02
	67	49.32	32.39	0.02	43.94	29.71	0.03	37.72	26.76	0.03	30.51	23.51	0.03	22.41	20.04	0.03
	62	40.19	34.31	0.03	34.71	31.44	0.03	28.63	28.30	0.04	23.57	23.57	0.11	19.71	19.71	0.25
1225	72	64.13	32.86	0.01	58.72	30.36	0.02	52.40	27.56	0.03	45.06	24.47	0.03	36.56	21.07	0.03
	67	53.55	35.72	0.04	47.80	32.91	0.04	41.11	29.81	0.04	33.40	26.40	0.04	24.73	22.69	0.05
	62	43.83	38.28	0.04	38.03	35.26	0.04	31.70	31.95	0.05	26.61	26.61	0.14	22.21	22.21	0.28
SIZE 36																
700	72	43.33	22.33	0.00	39.24	20.20	0.00	34.54	17.90	0.00	29.27	15.50	0.00	23.32	12.96	0.00
	67	35.55	23.09	0.01	31.29	20.81	0.01	26.53	18.39	0.01	21.15	15.88	0.01	15.36	13.31	0.01
	62	28.50	23.70	0.01	24.22	21.35	0.01	19.63	18.93	0.02	15.45	15.45	0.05	12.83	12.83	0.21
875	72	50.29	25.92	0.00	45.60	23.58	0.00	40.23	21.05	0.00	34.05	18.28	0.01	27.07	15.39	0.00
	67	41.42	27.22	0.01	36.53	24.66	0.02	30.93	21.90	0.02	24.68	19.03	0.02	17.98	16.12	0.02
	62	33.30	28.27	0.02	28.43	25.63	0.02	23.20	22.90	0.03	18.76	18.76	0.08	15.60	15.59	0.24
1050	72	55.99	28.96	0.00	50.88	26.52	0.00	44.98	23.76	0.01	38.16	20.78	0.02	30.32	17.54	0.02
	67	46.35	30.86	0.02	40.94	28.11	0.03	34.65	25.09	0.03	27.71	21.92	0.03	20.29	18.70	0.03
	62	37.45	32.47	0.03	32.02	29.55	0.03	26.34	26.56	0.04	21.73	21.73	0.12	18.08	18.08	0.26
1225	72	60.74	31.57	0.01	55.32	29.01	0.02	49.03	26.17	0.03	41.65	23.01	0.03	33.08	19.54	0.03
	67	50.52	34.11	0.04	44.70	31.22	0.04	37.94	28.03	0.04	30.30	24.61	0.04	22.35	21.12	0.05
	62	41.02	36.30	0.04	35.23	33.22	0.04	29.16	29.97	0.06	24.47	24.47	0.15	20.38	20.37	0.29
1400	72	64.78	33.88	0.03	59.07	31.25	0.03	52.43	28.31	0.04	44.65	25.02	0.04	35.54	21.38	0.04
	67	54.04	37.04	0.05	47.93	34.06	0.05	40.78	30.74	0.05	32.59	27.10	0.05	24.21	23.40	0.06
	62	44.12	39.84	0.05	38.06	36.62	0.06	31.77	33.15	0.08	27.00	27.00	0.18	22.51	22.51	0.32
SIZE 48																
875	72	57.42	29.42	0.00	52.45	26.85	0.00	46.71	24.03	0.00	40.18	21.03	0.00	32.63	17.80	0.00
	67	47.42	30.60	0.00	42.24	27.82	0.00	36.26	24.83	0.00	29.43	21.60	0.00	21.78	18.21	0.00
	62	38.36	31.59	0.00	32.96	28.62	0.00	26.96	25.49	0.01	21.02	21.02	0.03	17.57	17.57	0.19
1050	72	64.85	33.22	0.00	59.39	30.49	0.00	53.01	27.45	0.00	45.54	24.10	0.00	37.03	20.53	0.00
	67	53.78	35.04	0.00	47.89	31.97	0.00	41.20	28.70	0.00	33.53	25.10	0.01	24.88	21.33	0.01
	62	43.59	36.53	0.01	37.61	33.29	0.01	30.92	29.84	0.01	24.69	24.69	0.05	20.68	20.68	0.20
1225	72	71.17	36.52	0.00	65.31	33.68	0.00	58.44	30.50	0.00	50.32	26.94	0.00	40.86	23.04	0.00
	67	59.24	39.03	0.01	52.90	35.81	0.01	45.53	32.24	0.01	37.13	28.38	0.01	27.69	24.29	0.01
	62	48.20	41.12	0.01	41.70	37.66	0.01	34.53	33.97	0.02	28.20	28.20	0.07	23.64	23.64	0.22

1400	72	76.52	39.42	0.00	70.39	36.54	0.00	63.10	33.25	0.00	54.49	29.55	0.00	44.24	25.33	0.01
	67	63.96	42.66	0.01	57.26	39.33	0.01	49.36	35.56	0.01	40.30	31.47	0.01	30.25	27.12	0.02
	62	52.27	45.42	0.02	45.32	41.79	0.02	37.86	37.90	0.03	31.50	31.50	0.09	26.46	26.46	0.24
1600	72	81.70	42.36	0.00	75.29	39.42	0.00	67.76	36.07	0.01	58.64	32.20	0.01	47.74	27.81	0.01
	67	68.59	46.44	0.02	61.56	43.01	0.02	53.21	39.12	0.02	43.50	34.78	0.02	32.89	30.19	0.03
	62	56.34	50.00	0.02	49.07	46.20	0.03	41.28	42.13	0.04	34.99	34.99	0.12	29.45	29.45	0.26
1750	72	85.08	44.35	0.01	78.50	41.36	0.01	70.73	37.98	0.01	61.36	34.06	0.02	50.07	29.56	0.02
	67	71.64	49.07	0.02	64.38	45.58	0.02	55.79	41.62	0.02	45.66	37.13	0.03	34.67	32.39	0.04
	62	59.05	53.24	0.03	51.63	49.36	0.03	43.66	45.12	0.05	37.41	37.41	0.14	31.54	31.54	0.28
SIZE 60																
1050	72	76.72	37.31	0.00	70.53	34.32	0.00	63.26	31.00	0.00	54.72	27.31	0.00	44.87	23.33	0.00
	67	63.75	39.28	0.00	57.04	35.92	0.00	49.37	32.29	0.00	40.47	28.33	0.00	30.31	24.09	0.00
	62	51.77	40.86	0.00	44.85	37.28	0.00	36.98	33.42	0.00	29.15	29.15	0.03	24.49	24.49	0.18
1225	72	84.49	41.13	0.00	77.85	38.03	0.00	70.02	34.53	0.00	60.74	30.62	0.00	49.75	26.24	0.00
	67	70.49	43.87	0.00	63.25	40.34	0.00	54.75	36.39	0.00	44.98	32.11	0.00	33.84	27.49	0.01
	62	57.45	46.11	0.01	49.84	42.26	0.00	41.36	38.12	0.01	33.38	33.38	0.05	28.07	28.07	0.20
1400	72	91.12	44.48	0.00	84.15	41.32	0.00	75.88	37.72	0.00	66.00	33.63	0.00	54.14	28.99	0.00
	67	76.32	48.04	0.01	68.68	44.39	0.00	59.63	40.25	0.01	48.99	35.66	0.01	37.06	30.73	0.01
	62	62.46	51.03	0.01	54.28	46.94	0.01	45.37	42.59	0.01	37.36	37.36	0.07	31.50	31.50	0.22
1600	72	97.58	47.87	0.00	90.26	44.66	0.00	81.63	41.00	0.00	71.22	36.77	0.00	58.60	31.93	0.00
	67	82.11	52.42	0.01	74.04	48.65	0.01	64.49	44.38	0.01	53.05	39.51	0.01	40.39	34.28	0.02
	62	67.50	56.28	0.01	58.97	52.08	0.01	49.59	47.46	0.02	41.69	41.69	0.10	35.23	35.23	0.23
1750	72	101.79	50.20	0.00	94.24	46.95	0.00	85.37	43.24	0.00	74.69	38.94	0.01	61.65	33.96	0.01
	67	85.85	55.43	0.01	77.59	51.63	0.01	67.69	47.28	0.01	55.89	42.30	0.01	42.67	36.85	0.02
	62	70.88	60.02	0.02	62.20	55.73	0.02	52.49	50.96	0.03	44.77	44.77	0.11	37.90	37.90	0.25
2000	72	107.82	53.69	0.01	99.99	50.42	0.01	90.79	46.63	0.01	79.66	42.29	0.01	66.02	37.13	0.01
	67	91.23	60.09	0.02	82.69	56.25	0.02	72.42	51.79	0.02	60.17	46.63	0.02	46.16	40.91	0.03
	62	75.82	65.87	0.02	66.93	61.51	0.03	57.16	56.55	0.04	49.51	49.51	0.14	42.03	42.03	0.27

Definitions:

EWB - Entering Wet Bulb (°F)

LWB - Leaving Wet Bulb (°F)

TC - Total Cooling Capacity (1000 Btuh)

BF - Bypass Factor

MBH - 1000 Btuh

SNC - Sensible Heat Capacities (1000 Btuh)

CFM - Cubic Feet Per Minute

NOTES:

- Contact manufacturer for cooling capacities at conditions other than shown in table.
- Formulas:

$$\text{Leaving db} = \text{entering db} - \frac{\text{sensible heat cap.}}{1.09 \times \text{CFM}}$$

$$\text{Leaving wb} = \text{wb corresponding to enthalpy of air leaving coil (h}_{lwb})$$

$$h_{lwb} = h_{ewb} - \frac{\text{total capacity (Btuh)}}{4.5 \times \text{CFM}}$$
 where h_{ewb} = enthalpy of air entering coil. Direct interpolation is permissible. Do not extrapolate.
- SHC is based on 80°F db temperature of air entering coil. Below 80°F db, subtract (Correction Factor x CFM) from SHC. Above 80°F db, add (Correction Factor x CFM) to SHC.
- Bypass Factor = 0 indicates no psychometric solution. Use bypass factor of next lower EWB for approximation.

SHC CORRECTION FACTOR

BYPASS FACTOR	ENTERING AIR DRY-BULB TEMPERATURE °F (°C)					
	79 (26)	78 (26)	77 (25)	76 (24)	75 (24)	Under 75 (24)
	81 (27)	82 (28)	83 (28)	84 (29)	85 (29)	Over 85
	Correction Factor					
0.10	.098	1.96	2.94	3.92	4.91	Use formula shown below
0.20	0.87	1.74	2.62	3.49	4.36	
0.30	0.76	1.53	2.29	3.05	3.82	

Interpolation is permissible.

Correction Factor = $1.09 \times (1 - BF) \times (db - 80)$

Table 10 – Estimated Sound Power Level of Airflow from Duct (dB)

UNIT SIZE	CONDITIONS		OCTAVE BAND CENTER FREQUENCY*						
	CFM	Ext Static Pressure	63	125	250	500	1000	2000	4000
24	400	0.50	69.0	65.0	61.0	58.0	56.0	54.0	50.0
	600	0.50	70.8	66.8	62.8	59.8	57.8	55.8	51.8
	800	0.50	72.0	68.0	64.0	61.0	59.0	57.0	53.0
	1000	0.50	73.0	69.0	65.0	62.0	60.0	58.0	54.0
	1200	0.50	73.8	69.8	65.8	62.8	60.8	58.8	54.8
	1400	0.50	74.4	70.4	66.4	63.4	61.4	59.4	55.4
36	400	0.50	69.0	65.0	61.0	58.0	56.0	54.0	50.0
	600	0.50	70.8	66.8	62.8	59.8	57.8	55.8	51.8
	800	0.50	72.0	68.0	64.0	61.0	59.0	57.0	53.0
	1000	0.50	73.0	69.0	65.0	62.0	60.0	58.0	54.0
	1200	0.50	73.8	69.8	65.8	62.8	60.8	58.8	54.8
	1400	0.50	74.4	70.4	66.4	63.4	61.4	59.4	55.4
	1600	0.50	75.0	71.0	67.0	64.0	62.0	60.0	56.0
48	400	0.50	69.0	65.0	61.0	58.0	56.0	54.0	50.0
	600	0.50	70.8	66.8	62.8	59.8	57.8	55.8	51.8
	800	0.50	72.0	68.0	64.0	61.0	59.0	57.0	53.0
	1000	0.50	73.0	69.0	65.0	62.0	60.0	58.0	54.0
	1200	0.50	73.8	69.8	65.8	62.8	60.8	58.8	54.8
	1400	0.50	74.4	70.4	66.4	63.4	61.4	59.4	55.4
	1600	0.50	75.0	71.0	67.0	64.0	62.0	60.0	56.0
60	600	0.50	70.8	66.8	62.8	59.8	57.8	55.8	51.8
	800	0.50	72.0	68.0	64.0	61.0	59.0	57.0	53.0
	1000	0.50	73.0	69.0	65.0	62.0	60.0	58.0	54.0
	1200	0.50	73.8	69.8	65.8	62.8	60.8	58.8	54.8
	1400	0.50	74.4	70.4	66.4	63.4	61.4	59.4	55.4
	1600	0.50	75.0	71.0	67.0	64.0	62.0	60.0	56.0
	1800	0.50	75.5	71.5	67.5	64.5	62.5	60.5	56.5
	2000	0.50	76.0	72.0	68.0	65.0	63.0	61.0	57.0
2150	0.50	76.3	72.3	68.3	65.3	63.3	61.3	57.3	

* Estimated sound power levels have been derived using the method described in the 1987 ASHRAE Systems & Applications Handbook, chapter 52, p. 52.7.

PERFORMANCE DATA (cont)

Table 11 – Airflow Performance Correction Factors

HEATER kW	ELEMENTS	STATIC PRESSURE CORRECTION (in. wc)	
		Sizes 24–48	Size 60
0	0	+0.02	+0.03
5	1	+0.01	+0.02
8, 10	2	0	0
9, 15	3	–0.02	–0.03
20	4	–0.04	–0.06
18, 24, 30	6	–0.06	–0.10

The airflow performance table was developed using fan coils with 10-kW electric heaters (2 elements) in the units. For fan coils with heaters made up of a different number of

elements, the external available static at a given CFM from the table may be corrected by adding or subtracting pressure. Use table for this correction.

Table 12 – Air Delivery Performance Correction Component Pressure Drop (in. wc) at Indicated Airflow (Dry to Wet Coil)

UNIT SIZE	CFM										
	600	700	800	900	1000	1100	1200	1300	1400	1500	1600
24	0.012	0.016	0.022	0.028	0.034	0.040	0.049	—	—	—	—
36	—	0.026	0.034	0.042	0.052	0.063	0.075	0.083	0.091	0.098	0.110
48	—	0.006	0.008	0.010	0.012	0.015	0.017	0.020	0.023	0.027	0.030
UNIT SIZE	CFM										
	1100	1200	1300	1400	1500	1600	1700	1800	1900	2000	2100
60	0.013	0.016	0.018	0.020	0.023	0.027	0.030	0.034	0.039	0.044	0.048

Table 13 – Factory-Installed Filter Static Pressure Drop (in. wc)

UNIT SIZE	CFM								
	400	600	800	1000	1200	1400	1600	1800	2000
24	0.020	0.044	0.048	0.072	0.100	—	—	—	—
36	—	0.020	0.035	0.051	0.070	0.092	—	—	—
48	—	—	0.035	0.051	0.070	0.092	0.120	—	—
60	—	—	—	0.038	0.053	0.070	0.086	0.105	0.133

Table 14 – Units without Electrical Heat

UNIT SIZE	MTR HP	VOLTS/PH/HZ	MTR FLA	SINGLE CIRCUIT		BRANCH CIRCUIT Min Wire Size Awg*
				MCA	MOCP	
24	1/2	208/230/1/60	4.0	5.0	15	14
36						
48	3/4		5.7	7.1		
60						

*. Use copper wire only to connect unit. If other than uncoated (non-plated) 75°C copper wire (solid wire for 10 AWG and smaller, stranded wire for larger than 10 AWG) is used consult applicable tables of the National Electric Code (ANSI/NFPA 70).

NOTE: If branch circuit wire length exceeds 100 ft, consult NEC 210-19a to determine maximum wire length. Use 2% voltage drop.
FLA = Full Load Amps; MCA = Minimum Circuit Ampacity; MOCP = Maximum Overcurrent Protection

Table 15 – Electric Heaters

HEATER PART NO.	kW @ 240 V	VOLTS/PH	STAGES (kW OPERATING)	INTERNAL CIRCUIT PROTECTION	FAN COIL SIZE USED WITH	HEATING CAP.‡ @ 230V	INTELLIGENT HEAT CAPABLE* (kW)
EHC05BKN	5	230/1	5	None	All	15,700	-
EHC07BKN	8	230/1	8	None	All	25,100	-
EHC10BKN	10	230/1	10	None	All	31,400	-
EHC15BKF	15	230/1	5, 15	Fuse†	All	47,100	5, 10, 15
EHC20BKF	20	230/1	5, 20	Fuse†	All	62,800	5, 15, 20
EHC09BKCN	9	230/1‡	3, 9	None	All	28,200	3, 6, 9
EHC15BHN	15	230/1	5, 15	None	All	47,100	-
EHC18DHN	18	230/1	6, 12, 18	None	All	56,500	-
EHC25DHCF	24	230/1**	8, 16, 24	Fuse	48, 60	78,300	8, 16, 24
EHC30DHCF	30	230/1**	10, 20, 30	Fuse	48, 60	94,100	10, 20, 30
EHC05BKB	5	230/1	5	Circuit Breaker	All	15,700	-
EHC07BKB	8	230/1	8	Circuit Breaker	All	25,100	-
EHC10BKB	10	230/1	10	Circuit Breaker	All	31,400	-
EHC15BKB	15	230/1	5, 15	Circuit Breaker	All	47,100	5, 10, 15
EHC20BKB	20	230/1	5, 20	Circuit Breaker	All	62,800	5, 15, 20

*. Heaters designed with kW operating values are intelligent heat capable when used with compatible thermostat.

†. Single circuit application of F15 and F20 heaters requires Single-point wiring kit accessory.

‡. Field convertible to 3 phase.

** . These heaters are field convertible to 1 phase, single or multiple supply circuit.

NOTE: for 240 volts, multiply 230V heater amps by 1.04.

Table 16 – Electric Heater Internal Protection

HEATER kW	FUSES QTY/SIZE	CKT BKR QTY/SIZE (all are 2-pole)
5	—	1/60
8	—	1/60
9	—	—
10	—	1/60
15	2/30, 2/60	2/60
15	—	—
18	—	—
20	4/60	2/60
24	6/60	—
30	6/60	—

Table 17 – Electric Heater Electrical Data

FC Size	Motor FLA used	HEATER PART NO.	kW		P H A S E	Internal Circuit Protection	HEATER AMPS 208/230V [†]			MIN AMPACITY 208/230V [†]			BRANCH CIRCUIT								
													Min Wire Size (AWG) 208/230V [†]			Min Gnd Wire Size 208/230V [†]			Max Fuse/Ckt Bkr Amps 208/230V		
			240V	208V			Single Circuit	Dual Circuit		Single Circuit	Dual Circuit		Single Circuit	Dual Circuit		Single Circuit	Dual Circuit		Single Circuit	Dual Circuit	
			L1,L2	L3,L4		L1,L2	L3,L4		L1,L2	L3,L4		L1,L2	L3,L4		L1,L2	L3,L4					
24-36	4.0	EHC05BKN	5	3.8	1	None	17.8/19.7	—	—	27.3/29.6	—	—	10/10	—	—	10/10	—	—	30/30	—	—
24-36	4.0	EHC05BKB	5	3.8	1	Ckt Bkr	17.8/19.7	—	—	27.3/29.6	—	—	10/10	—	—	10/10	—	—	30/30	—	—
48-60	5.7	EHC05BKN	5	3.8	1	None	17.8/19.7	—	—	29.4/31.8	—	—	10/8	—	—	10/10	—	—	30/35	—	—
48-60	5.7	EHC05BKB	5	3.8	1	Ckt Bkr	17.8/19.7	—	—	29.4/31.8	—	—	10/8	—	—	10/10	—	—	30/35	—	—
24-36	4.0	EHC07BKN	8	6.0	1	None	28.5/31.5	—	—	40.6/44.4	—	—	8/8	—	—	10/10	—	—	45/45	—	—
24-36	4.0	EHC07BKB	8	6.0	1	Ckt Bkr	28.5/31.5	—	—	40.6/44.4	—	—	8/8	—	—	10/10	—	—	45/45	—	—
48-60	5.7	EHC07BKN	8	6.0	1	None	28.5/31.5	—	—	42.8/46.5	—	—	8/8	—	—	10/10	—	—	45/50	—	—
48-60	5.7	EHC07BKB	8	6.0	1	Ckt Bkr	28.5/31.5	—	—	42.8/46.5	—	—	8/8	—	—	10/10	—	—	45/50	—	—
24-36	4.0	EHC10BKN	10	7.5	1	None	35.6/39.4	—	—	49.5/54.3	—	—	8/6	—	—	10/10	—	—	50/60	—	—
24-36	4.0	EHC10BKB	10	7.5	1	Ckt Bkr	35.6/39.4	—	—	49.5/54.3	—	—	8/6	—	—	10/10	—	—	50/60	—	—
48-60	5.7	EHC10BKN	10	7.5	1	None	35.6/39.4	—	—	51.6/56.4	—	—	6/6	—	—	10/10	—	—	60/60	—	—
48-60	5.7	EHC10BKB	10	7.5	1	Ckt Bkr	35.6/39.4	—	—	51.6/56.4	—	—	6/6	—	—	10/10	—	—	60/60	—	—
36	4.0	EHC09BKCN [‡]	9	6.8	1	None	32.2/35.6	—	—	45.3/49.5	—	—	8/6	—	—	10/10	—	—	50/50	—	—
36	4.0	EHC09BKCN	9	6.8	3	None	18.6/20.6	—	—	28.3/30.8	—	—	8/8	—	—	10/10	—	—	30/35	—	—
48-60	5.7	EHC09BKCN [‡]	9	6.8	1	None	32.2/35.6	—	—	47.4/51.6	—	—	8/6	—	—	10/10	—	—	50/60	—	—
48-60	5.7	EHC09BKCN	9	6.8	3	None	18.6/20.6	—	—	30.4/32.9	—	—	8/8	—	—	10/10	—	—	35/35	—	—
24-36	4.0	EHC15BKF ^{**}	15	11.3	1	Fuse	53.4/59.1	35.6/39.4	17.8/19.7	71.8/78.9	49.5/54.3	22.3/24.6	4/4	8/6	10/10	8/8	10/10	10/10	80/80	50/60	25/25
24-36	4.0	EHC15BKB	15	11.3	1	Ckt Bkr	53.4/59.1	35.6/39.4	17.8/19.7	71.8/78.9	49.5/54.3	22.3/24.6	4/4	8/6	10/10	8/8	10/10	10/10	80/80	50/60	25/25
48-60	5.7	EHC15BKF ^{**}	15	11.3	1	Fuse	53.4/59.1	35.6/39.4	17.8/19.7	73.9/81.0	51.6/56.4	22.3/24.6	4/4	6/6	10/10	8/8	10/10	10/10	80/90	60/60	25/25
48-60	5.7	EHC15BKB	15	11.3	1	Ckt Bkr	53.4/59.1	35.6/39.4	17.8/19.7	73.9/81.0	51.6/56.4	22.3/24.6	4/4	6/6	10/10	8/8	10/10	10/10	80/90	60/60	25/25
36	4.0	EHC15BHN	15	11.3	3	None	30.8/34.1	—	—	43.5/47.6	—	—	8/6	—	—	10/10	—	—	50/50	—	—
48-60	5.7	EHC15BHN	15	11.3	3	None	30.8/34.1	—	—	45.6/49.8	—	—	8/6	—	—	10/10	—	—	50/50	—	—
48-60	5.7	EHC18DHN	18	13.5	3	None	37.2/41.2	—	—	53.6/58.6	—	—	6/6	—	—	10/10	—	—	60/60	—	—
36	4.0	EHC20BKF ^{**}	20	15.0	1	Fuse	71.2/78.8	35.6/39.4	35.6/39.4	94.0/103.5	49.5/54.3	44.5/49.3	3/2	6/6	8/8	8/6	10/10	10/10	100/110	50/60	45/50
36	4.0	EHC20BKB	20	15.0	1	Ckt Bkr	71.2/78.8	35.6/39.4	35.6/39.4	94.0/103.5	49.5/54.3	44.5/49.3	3/2	6/6	8/8	8/6	10/10	10/10	100/110	50/60	45/50
48-60	5.7	EHC20BKF ^{**}	20	15.0	1	Fuse	71.2/78.8	35.6/39.4	35.6/39.4	96.3/105.6	51.6/56.4	44.5/49.3	3/2	6/6	8/8	8/6	10/10	10/10	100/110	60/60	45/50
48-60	5.7	EHC20BKB	20	15.0	1	Ckt Bkr	71.2/78.8	35.6/39.4	35.6/39.4	96.3/105.6	51.6/56.4	44.5/49.3	3/2	6/6	8/8	8/6	10/10	10/10	100/110	60/60	45/50
48-60	5.7	EHC25DHCF ^{††}	24	18.0	3	Fuse	49.3/54.6	—	—	68.8/75.4	—	—	4/4	—	—	8/8	—	—	70/80	—	—
48-60	5.7		24	18.0	1	Fuse	85.5/94.5	—	—	114.0/125.3	—	—	2/1	—	—	6/6	—	—	125/150	—	—
48-60	5.7	EHC30DHCF ^{††}	30	22.5	3	Fuse	61.7/68.2	—	—	84.3/92.4	—	—	4/3	—	—	8/8	—	—	90/100	—	—
48-60	5.7		30	22.5	1	Fuse	106.8/118.1	—	—	140.6/154.8	—	—	0/00	—	—	6/6	—	—	150/175	—	—

*. For 240V, multiply 230V heater amps by 1.04. Wire sizing and over-current protection may need adjustment per local code requirements.

†. Copper wire must be used. If other than uncoated (non-plated), 75°C ambient, copper wire (solid wire for smaller, and stranded wire for larger than 10 AWG) is used, consult applicable tables of the National Electric Code (ANSI/NFPA 70).

‡. Field convertible to 3 phase.

** Single circuit application of F15 and F20 heaters requires Single-point wiring kit accessory.

†† Field convertible to 1 phase, single or multiple supply circuit.

Table 18 – Field Multipoint Wiring or 24- and 30-kW Single Phase

FC Size	Motor FLA used	HEATER PART NO.	kW		PHASE	HEATER AMPS 208/230V			MIN AMPACITY 208/230V [†]			MIN WIRE SIZE (AWG) 208/230V [†]			MIN GND WIRE SIZE 208/230V	MAX FUSE/CKT BKR AMPS 208/230V		
			240V	208V		L1,L2	L3,L4	L5,L6	L1,L2	L3,L4	L5,L6	L1,L2	L3,L4	L5,L6		L1,L2	L3,L4	L5,L6
48-60	5.7	EHC25DHCF [‡]	24	18.0	1	28.5/31.5	28.5/31.5	28.5/31.5	42.8/46.5	35.6/39.4	35.6/39.4	8/8	8/8	8/8	10/10	50/50	40/40	40/40
48-60	5.7	EHC30DHCF [‡]	30	22.5	1	35.6/39.4	35.6/39.4	35.6/39.4	51.6/56.4	44.5/49.3	44.5/49.3	6/6	8/8	8/8	10/10	60/60	45/50	45/50

*. Includes blower motor amps of largest fan coil used with heater.

†. Copper wire must be used. If other than uncoated (non-plated), 75°C ambient, copper wire (solid wire for 10 AWG and smaller, stranded wire for larger than 10 AWG) is used, consult applicable tables of the NEC (ANSI/NFPA 70).

‡. Field convertible to 1 phase, single or multiple supply circuit.

Manufacturer reserves the right to change, at any time, specifications and designs without notice and without obligations.

ACCESSORIES**Table 19 – Accessories**

	ITEM	ACCESSORY PART NO.*	FAN COIL SIZE USED WITH
1.	Disconnect Kit	KFADK0301DSC	All single phase 3kW - 10kW heaters
2.	Downflow Base Kit	EBAC02NCB	24
		EBAC03NCB	36, 48
		EBAC04NCB	60
3.	Downflow Conversion Kit †	EBAC01DFS	Slope Coil Units—36
		EBAC02DFA	A-Coil Units—24, 48, 60
4.	Downflow/Horizontal Conversion Gasket Kit	EBAC01GSK	All
5.	Horizontal Water Management Kit (25 pack) ‡	NAMA00125HC	A-Coil Units—24, 48, 60
6.	Single-Point Wiring Kit	EBAC01SPK	Only with 15- and 20-kW Fused Heaters
7.	Filter	See Table 3 for filter dimensional details.	
8.	Fan Coil Filter Cabinet (Fan Coil Filter Media)	AHIC0017A (FAIC0017A2)	24
		AHIC0021A (FAIC0021A2)	36, 48
		AHIC0024A (FAIC0024A2)	60
9.	PVC Condensate Trap Kit (50 pack)	EBAC01CTK	All
10.	Door Gasket Kit **	1191140	All
11.	Accessory Quick Connect Kit	NAMA00110QC	All

* Factory authorized and listed, field-installed.

** This kit is for replacement of factory installed gaskets if they are damaged or removed from the fan coil.

† EBAC01GSK must also be purchased for down flow applications.

‡ EBAC01GSK must also be purchased for down flow or horizontal applications.

Accessory Kits Description Suggested and Required Use

1. Disconnect Kit

The kit is used to disconnect electrical power to the fan coil so service or maintenance may be performed safely.

SUGGESTED USE: Units for 3- through 10-kW electric resistance heaters and cooling controls.

2. Downflow Base Kit

This kit is designed to provide a 1-in. (25MM) minimum clearance between unit discharge plenum, ductwork, and combustible materials. It also provides a gap-free seal with the floor.

REQUIRED USE: This kit must be used whenever fan coils are used in downflow applications.

3. Downflow Conversion Kit

Fan coils are shipped from the factory for upflow or horizontal-left applications. Downflow conversion kits provide proper condensate water drainage and support for the coil when used in downflow applications. Separate kits are available for slope coils and A-coils.

REQUIRED USE: This kit must be used whenever fan coils are used in downflow applications.

4. Downflow/Horizontal Conversion Gasket Kit

This kit provides the proper gasketing of units when applied in either a downflow or horizontal application.

REQUIRED USE: Fan coils in either downflow or horizontal applications.

5. Horizontal Water Management Kit

This kit provides proper installation of fan coils under conditions of high static pressure and high relative humidity.

SUGGESTED USE: All fan coils.

6. Single Point Wiring Kit

The single point wiring kit acts as a jumper between L1 and L3 lugs, and between the L2 and L4 lugs. This allows the installer to run 2 heavy-gauge, high-voltage wires into the fan coil rather than 4 light-gauge, high-voltage wires.

SUGGESTED USE: Fan coils with 15- and 20-kW fused heaters only.

7. Filters

These filters collect large dust particles from the return air entering the fan coil and prevents them from collecting on the coil. This process helps to keep the coil clean, which increases heat transfer and, in turn, the efficiency of the system.

SUGGESTED USE: To replace filters in fan coils.

REQUIRED USE: All units unless a filter grille is used.

8. Fan Coil Filter Cabinet

This cabinet is mounted to the fan coil on the return air end and designed to slip over the outer fan coil casing. The cabinets are insulated using the same insulation as production fan coils. They are designed for the removal of particulates from indoor air using FAIC00XXA2 (17, 21, 24) media filter cartridges. These fan coil media filter cartridge kits are designed for the removal of particles from indoor air. The cartridge is installed in the return air duct next to the air handler or further upstream.

SUGGESTED USE: All fan coils.

9. Condensate Drain Trap Kit

This kit consists of 50 PVC condensate traps. Each trap is pre-formed and ready for field installation. This deep trap helps the system make and hold proper condensate flow even during blower initiation.

SUGGESTED USE: All fan coils.

10. Door Gasket Kit

This kit consists of specific adhesive-backed foam strips which are applied to the unit door and frame, limiting air leakage.

11. Accessory Quick Connect Kit

This kit enables the installer to easily connect a 230V IAQ accessory (air purifier, electronic air cleaner, UV light, etc.) kit to a fan coil unit, eliminating the need to run a separate power supply to the accessory. Use of this kit may eliminate the requirement for a licensed electrician to complete the job (check local codes).