

Job Name:	
Submitted By:	



Submittal Sheet For:	WT009GLSI25HLH / YN009GLSI25RPH
-----------------------------	--

Date _____
 Ref. _____

Wall-Mounted Ductless 25SEER Inverter Heat Pump

System Full Set Model: **WYT009GLSI25RH**

AHRI Reference Number: **217048754**

Cooling Mode Performance

Rated Cooling	9,000 BTU/hr
Ambient Range	5~131°F
SEER2 Rating	25.0 BTU/W·h
EER2 Rating	14.5 BTU/W·h

* 100% Capacity @ Indoor DB 80°F / WB 67°F

Heating Mode Performance

Rated Heating	9,000 BTU/hr
Ambient Range	-22~86°F
HSPF2 IV (V)	10.5 (9.0) BTU/W·h
COP2 (47°F)	4.0 W/W

Heating (17°F) = 10,000 BTU / Heating (5°F) = 9,100 BTU / COP2 (5°F) = 1.8 W/W



Wall-Mounted Indoor Unit



Outdoor Condensing Unit



User-Selected Installation Kit



Handheld Remote Controller

Electrical Information

Rated Input (W)	Cooling	Heating
	680	730
Rated Current (A)	3.0	3.3
Breaker Needed	15A (Double-Pole)	
Power Supply	208~230V, 60Hz, 1Ph	

Piping and Refrigerant

Liquid Line (OD)	1/4 in
Suction Line (OD)	3/8 in
Refrigerant Precharge	R-454b(Supports 10-50ft.)
Max Length/Height Diff.	50 ft. / 33 ft.

This combination is Energy-Star certified.



Interior Unit (Air Handler) Specifications

Type	Heat Pump
Sound Level (dBA)	42 (Turbo) / 39 (Hi) / 33 (Med) / 29 (Lo) / 26 (Mute)
Auto Air Circulation	2-Way Louver (Up-Down + Left-Right)
Dimensions (WDH)	32-1/4 in x 7-5/8 in x 12 in
Weight (lbs)	20.7

Exterior Unit (Condenser) Specifications

Sound Level (dBA)	55
Recommended Room Size	250~350 Sq. ft.
Minimum Room Size	38 Sq. ft.
Compressor	Inverter-Driven Rotary
Dimensions (WDH)	31-7/8 in x 12 in x 21-5/8 in
Weight (lbs)	54.0

WT009GLSI25HLH Air Handler Dimensional Data

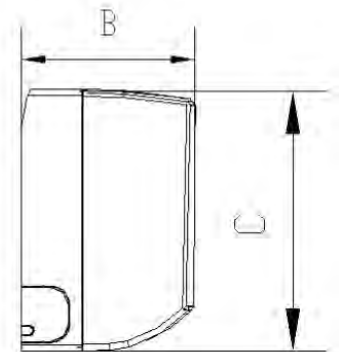
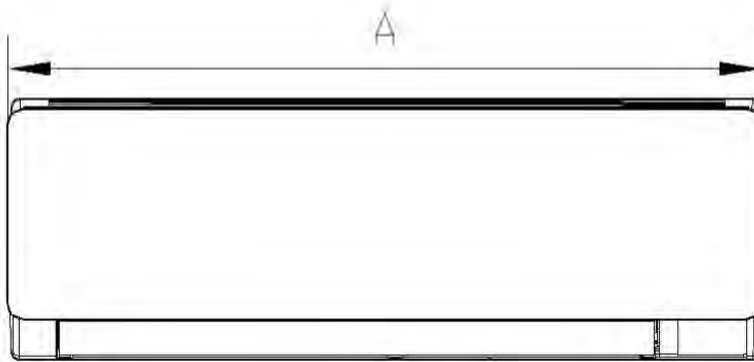
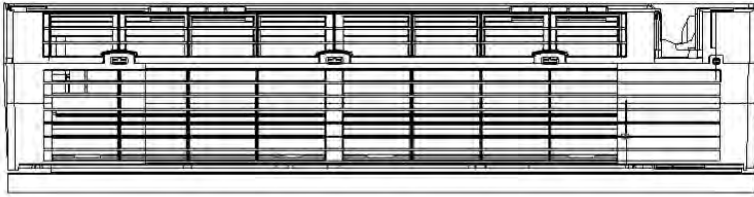

Model	A	B	C
WT009GLSI25HLH	32-1/4 in	7-5/8 in	12 in
	820 mm	193 mm	304.8 mm

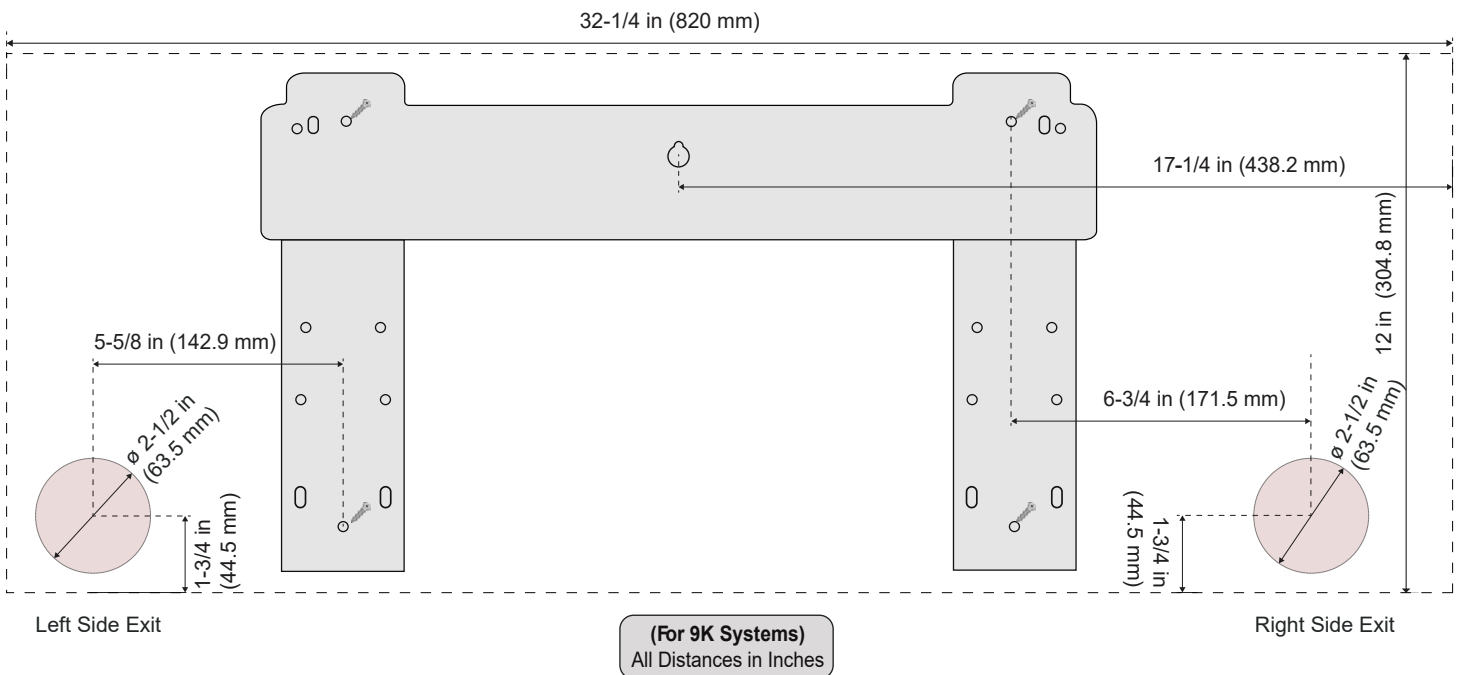

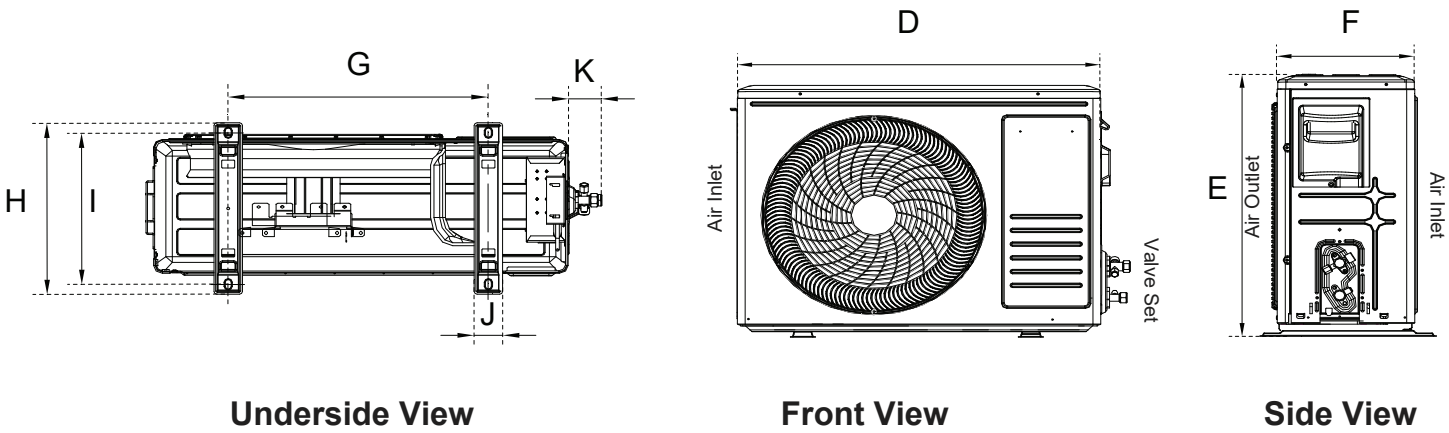

Model	D	E	F	G	H	I	J	K
YN009GLSI25RPH	29-1/4 in	21-3/4 in	10 in	17-1/8 in	12 in	11 in	1-7/8 in	2-1/4 in
	741 mm	551 mm	253 mm	434 mm	304.8 mm	278 mm	48 mm	58 mm

Warranty Information and Length



Complete warranty details are available with the vendor or online at <https://www.pdhvac.com/support/warranty/>. This high quality system is eligible for up to 10 years limited warranty on the compressor, and 7 years on other internal parts. To qualify for this warranty, the system must be installed within 90 days by a registered technician. All other installations that are registered default to 5 years parts/compressor. Products unregistered qualify for only 1 year parts/compressor warranty.

Outstanding Features

- LED Display
- Energy Saving
- Ultra-Thin Design
- Dual Drain Options
- Customizable Timer
- Eco-Friendly Refrigerant
- Whisper-Quiet Operation
- Power Loss Memory Recovery



Available Accessories

Part Number	Description
IKT-LCVR4P-KIT	<i>Decorative PVC Line Cover Kit</i>
IKT-LNBR-1/4-3/8	<i>BendAid Flexible Easy Bender Kit</i>
BRK-FRM-C-2P	<i>Folding Mounting Bracket w/ Leveler</i>
IKT-UVL32UL-AG	<i>UVC Bacterial Disinfection Kit</i>
IKT-SURPRK-DV2	<i>Ultimate Surge and Power Protection</i>