

Job Name:	
Submitted By:	



Submittal Sheet For: **WT024GLSI25HLH / YN024GLSI25RPH**

Date \_\_\_\_\_  
 Ref. \_\_\_\_\_

**Wall-Mounted Ductless 22SEER Inverter Heat Pump**

System Full Set Model: **WYT024GLSI25RH**

AHRI Reference Number: **217048757**

**Cooling Mode Performance**

Rated Cooling	24,000 BTU/hr
Ambient Range	5~131°F
SEER2 Rating	22.5 BTU/W·h
EER2 Rating	11.7 BTU/W·h

\* 100% Capacity @ Indoor DB 80°F / WB 67°F

**Heating Mode Performance**

Rated Heating	24,000 BTU/hr
Ambient Range	-22~86°F
HSPF2 IV (V)	10.0 (8.6) BTU/W·h
COP2 (47°F)	3.3 W/W

Heating (17°F) = 24,000 BTU / Heating (5°F) = 22,400 BTU / COP2 (5°F) = 1.8 W/W



Wall-Mounted Indoor Unit



Outdoor Condensing Unit



User-Selected Installation Kit



Handheld Remote Controller

**Electrical Information**

	Cooling	Heating
Rated Input (W)	1,860	2,000
Rated Current (A)	8.3	9.0
Breaker Needed	30A (Double-Pole)	
Power Supply	208~230V, 60Hz, 1Ph	

**Piping and Refrigerant**

Liquid Line (OD)	1/4 in
Suction Line (OD)	5/8 in
Refrigerant Precharge	R-454b(Supports 10-50ft.)
Max Length/Height Diff.	65 ft. / 50 ft.

**Interior Unit (Air Handler) Specifications**

Type	Heat Pump
Sound Level (dBA)	49 (Turbo)/47 (Hi)/42 (Med)/37 (Lo)/32 (Mute)
Auto Air Circulation	2-Way Louver (Up-Down + Left-Right)
Dimensions (WDH)	43-1/8 in x 8-3/4 in x 13-1/8 in
Weight (lbs)	30.9

**Exterior Unit (Condenser) Specifications**

Sound Level (dBA)	61
Recommended Room Size	750~1,000 Sq. ft.
Minimum Room Size	63 Sq. ft.
Compressor	Inverter-Driven Rotary
Dimensions (WDH)	38-1/2 in x 16-5/8 in x 31-5/8 in
Weight (lbs)	108

This combination is Energy-Star certified.



# WT024GLSI25HLH Air Handler Dimensional Data

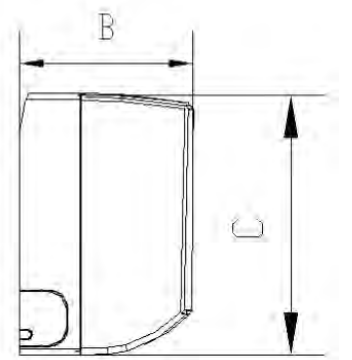
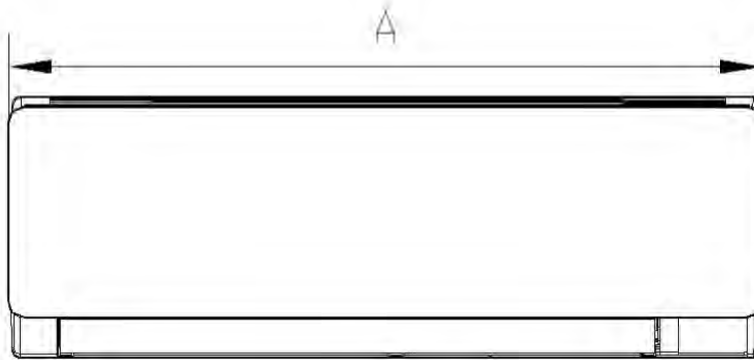

Model	A	B	C
WT024GLSI25HLH	43-1/8 in	8-3/4 in	13-1/8 in
	1,096 mm	222.3 mm	334 mm

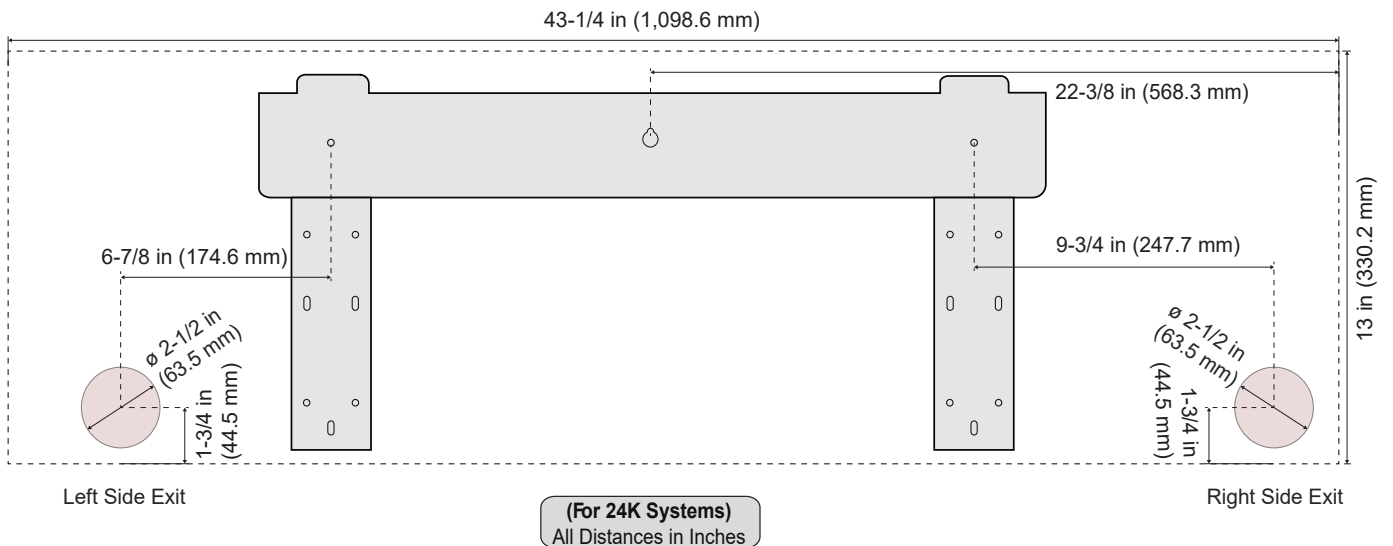

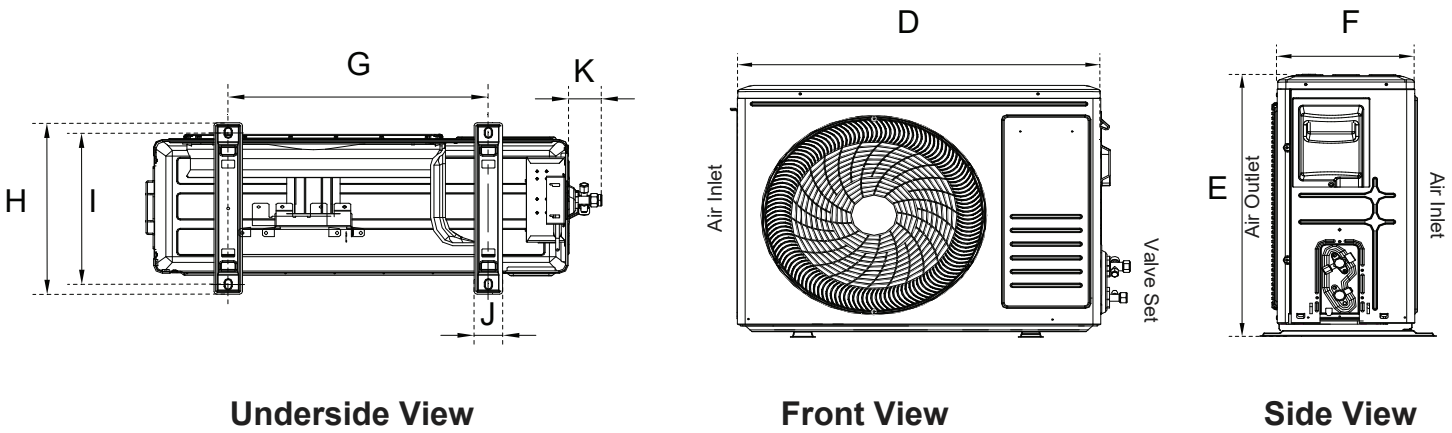

Model	D	E	F	G	H	I	J	K
YN024GLSI25RPH	35-7/8 in	31-5/8 in	13-7/8 in	23-7/8 in	16-5/8 in	15-3/8 in	2-1/2 in	2-1/8 in
	910 mm	804 mm	353 mm	607 mm	421 mm	390 mm	63 mm	54 mm

### Warranty Information and Length



Complete warranty details are available with the vendor or online at <https://www.pdhvac.com/support/warranty/>. This high quality system is eligible for up to 10 years limited warranty on the compressor, and 7 years on other internal parts. To qualify for this warranty, the system must be installed within 90 days by a registered technician. All other installations that are registered default to 5 years parts/compressor. Products unregistered qualify for only 1 year parts/compressor warranty.

### Outstanding Features

- LED Display
- Energy Saving
- Ultra-Thin Design
- Dual Drain Options
- Customizable Timer
- Eco-Friendly Refrigerant
- Whisper-Quiet Operation
- Power Loss Memory Recovery



### Available Accessories

Part Number	Description
IKT-LCVR4P-KIT	<i>Decorative PVC Line Cover Kit</i>
IKT-LNBR-1/4-3/8	<i>BendAid Flexible Easy Bender Kit</i>
BRK-FRM-C-2P	<i>Folding Mounting Bracket w/ Leveler</i>
IKT-UVL32UL-AG	<i>UVC Bacterial Disinfection Kit</i>
IKT-SURPRK-DV2	<i>Ultimate Surge and Power Protection</i>